

# EPS14P

## OPERATOR MANUAL

< OM-EPS14P2019001-EN >



BYD FORKLIFT

# EPS14P

## OPERATOR MANUAL

< OM-EPS14P2019001-EN >



BYD FORKLIFT

# TABLE OF CONTENTS

## FOREWORD

### FOREWORD

Operation Notice	9
Forklift Delivery	9

## OPERATOR NOTICE

### Notice

Operator Qualification	11
Warning decals and signs	12

## INTRODUCTION

### View, Technical Specifications and Operating Environment

General View	14
Technical Specifications	15
Vehicle Drawing	15
Technical Specifications	16
Working Environment	17

### Nameplate and decals

Forklift nameplate	18
Battery Nameplate	19
Loading Capacity Chart	19
Other decals	20

## OPERATING

### Startup and Control

Key Switch	22
------------	----

Emergency Disconnect Switch	22
Fork carriage and pedal	22
Tiller	23
Travel, Steering and Braking	23
Low Speed Control	25
Fork Lifting and Lowering	25
Horn	26
Emergency Reversal Switch	26

### Display

Display	27
---------	----

### Transporting Loads

Loading	28
Travelling	29
Unloading	30
Exiting	30

### Battery

Charging	30
----------	----

## TRANSPORTATION AND STORAGE

### Loading, Transportation and Unloading

Hoisting	32
Driving into the Transport vehicle	32
Transporting and Unloading	33

### Store and Restart

Procedures of Store	34
Procedures to Restart	34

## MAINTENANCE

### Daily Maintenance

Period and Items	36
Content Description	36

### Regular Maintenance

Period and Items	39
Content Description	39

### Consumable Items

Type and Parameters of Consumable Items	41
---	----

### Before Maintenance

Before Maintenance	42
Emergency Lowering	42
Move the Vehicle with the Electric Fault	42

### Chassis System Maintenance

Balance Inspection and Adjustment	44
Load Wheel Replacement	45
Caster Wheel Replacement	46
Driving Wheel Replacement	46
Gear Oil Level Checking	47
Gear Oil Replacement	48

### Mast Maintenance

Chains Adjustment	49
Chains Lubrication	51
Mast Cleaning	51
Mast Clearance Adjustment	52

### Hydraulic System Maintenance

Hydraulic Oil Filling	54
-----------------------	----

Hydraulic Oil Replacement	55
---------------------------	----

### Electric System Maintenance

Electrical Wiring Inspection	57
Main Controller Inspection	57
Low Voltage Fuse and Relay Inspection	58

### Torque Inspection on Critical Fasteners

Torque Inspection on Wheel Fasteners	59
Mast Fasteners Torque Checking	60

### Schematics

Hydraulic Schematic	61
Schematic of Electrical System	62

### Fault Code Table

Fault Code Table	63
------------------	----

## OTHER INFORMATION

OTHER INFORMATION	72
-------------------	----

## FOREWORD

Thank you for choosing BYD electric forklifts.

These operating instructions explain in detail how to correctly operate the BYD electric forklifts, as well as the procedures that you should follow when conducting checks, maintenance and repairs on the forklifts.

Read through every chapter in the manual before operation for the correct use and maintenance of the forklifts. When the forklift is out for rental or transportation, keep this operation instruction together with the forklift and make sure that operators can use the manual whenever necessary.

Pay attention to the following signs:

### Danger

(Indicates an imminent extremely hazardous situation. Failure to avoid it will cause severe injuries, major property damage or even death)

### Warning

(Indicates a potential extremely hazardous situation. Failure to avoid it might cause severe injuries, major property damage or even death)

### Caution

(Indicates a potential hazardous situation. Failure to avoid it might cause slight to medium injuries, or property damage)

### Note

(Note for detailed operation. Complying with the instructions will ensure a better operation of the BYD forklift)

## DESCRIPTIONS

### Operation Notice

BYD industrial vehicles can only be operated in the designated areas in the factory or in other specific environments, in compliance with Regulations on safety supervision of special equipment.

Inappropriate use of the BYD forklift might cause damages and losses, which the operators or proprietor instead of BYD should be held liable for. If the forklift needs to be operated in the environments other than those mentioned in this manual, contact with your local BYD dealer first for confirmation.

Any modification to the forklift is not allowed unless BYD's written consent is granted. Contact with BYD first before modifying the forklifts.

If you have ordered other auxiliary attachments besides forks, please handle the loads in compliance with the loading capacity of the attachments. All the attachments are provided with operation instructions. Read through the manuals before operation.

This manual is devised based on the standard forklifts. For other questions not covered in the manual, please check with BYD after sales service.

BYD forklift is subject to ongoing development and optimizing the design of products. BYD Forklift reserves the right to alter the design, equipment, technical features, and technical specifications and so on. No guarantee of particular features of the forklift should therefore be assumed from the present operator manual.

### Forklift Delivery

Every BYD forklift has passed through thorough performance tests before shipment. Although proper protection has also been adopted during transportation, it is advised to conduct a thorough inspection when the forklift arrives. Before delivering the forklift to end customers, to guarantee that the forklift is in perfect condition, the followings checks should be conducted at BYD dealers:

- (1) Check if the wheel nuts are securely fastened
- (2) Check the hydraulic oil level
- (3) Check the braking function
- (4) Check the travelling function
- (5) Check the steering function
- (6) Check the operation of mast and attachments
- (7) Check the high voltage connectors (transportation might have loosened the connectors)

To avoid inconveniences in future warranty claims, please check the functions of the forklift and check if the forklift is complete.

## OPERATOR NOTICE

This chapter instructs on safety operation procedures that should be followed during the use of the BYD forklift.

The operator of the forklift should have obtained the driving permit in accordance with local regulations.

Before operating the forklift, check the nameplate and capacity chart to know the loading capacity of the forklift and avoid the overloading during operation.

Warning signs and decals are pasted on the forklift. Get familiar with the decals and its contents.

## NOTICE

### Operator Qualification

Industrial vehicle can only be allowed to be operated by people with the qualification regulated by local laws. The operators should be those who have been specially trained and have experience in operating the vehicles. The user or other entrusting part must confirm the qualification of the operators and make use of the tests before authorizing the person to operate the forklift.

The operating company must make sure that the operators understand all the safety messages on the forklifts.

For the proprietor, make sure following safety instruction on your industrial vehicles are observed.

Please abide by relevant regulations and guide-principles, such as:

- (1) Operation of industrial vehicle
- (2) Lane and operative area regulation
- (3) Driver's right, responsibility and standard of behavior
- (4) Special operation area
- (5) Daily maintenance and repair
- (6) Regular maintenance and repair

#### Danger

- (1) Unauthorized persons are not allowed to operate the forklift.
- (2) Safety devices and features will provide extra safety. Do not deactivate these safety device and features.
- (3) Make sure that the load is well palletized and trimmed to avoid its protruding the loading surface of forklift and thus slipping, collapsing and falling over.
- (4) Any modification on the forklift is not allowed. Contact with BYD before making any modification.
- (5) Do not overload. Before operation, please check the rated loading capacity and loading center on the capacity chart. When an attachment has been installed, abide by the rated loading capacity given on the attachment.
- (6) Do not operate the forklift after drinking. It might cause severe human injuries.

Caution

- (1) Read through the operation instructions before operating the forklift.
- (2) Operators should wear working boots and working clothes.
- (3) Do not operate the forklift with wet or greased hands.
- (4) Conduct the daily checking and regular maintenance on the forklift.
- (5) Stop operating the forklift when the abnormalities and damages are found on the forklift.  
Do not use the forklift until the forklift is fully repaired.

**Warning decals and signs**

The BYD forklifts have warning decals and signs to remind the operators of potential risks, as well as safety notices. Find and read all these decals and signs.

If the warning decals and signs are missing or difficult to read, please contact your local BYD dealer for immediate replacement.

**INTRODUCTION**

This chapter instructs on the general view and technical specifications of the forklift.

VIEW, TECHNICAL SPECIFICATIONS AND OPERATING ENVIRONMENT

General View

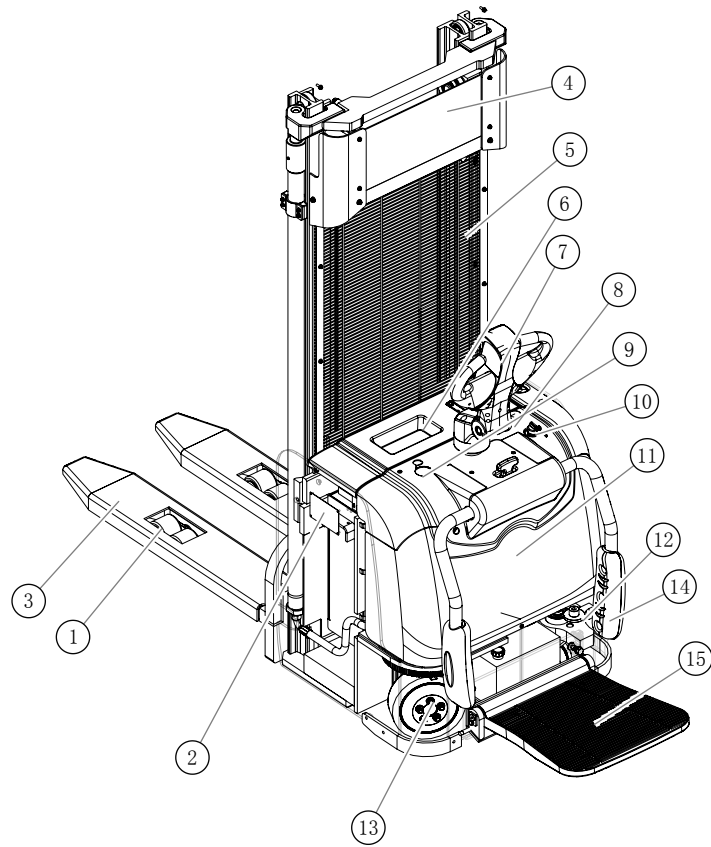

No.	Name	No.	Name	No.	Name
1	Fork Load Wheel	6	Battery Cover	11	Cover
2	Forklift nameplate	7	Tiller	12	Castor Wheel
3	Fork	8	Emergency Disconnect Switch	13	Drive Wheel
4	Mast	9	Display	14	Fork Carriage
5	Protection Mesh	10	Key Switch	15	Pedal

Technical Specifications

Vehicle Drawing

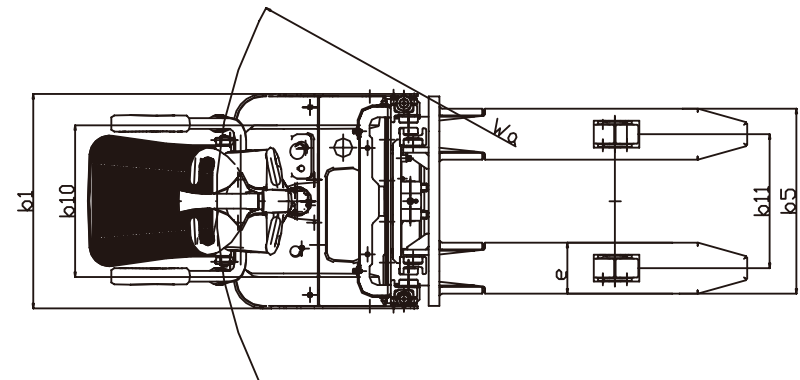
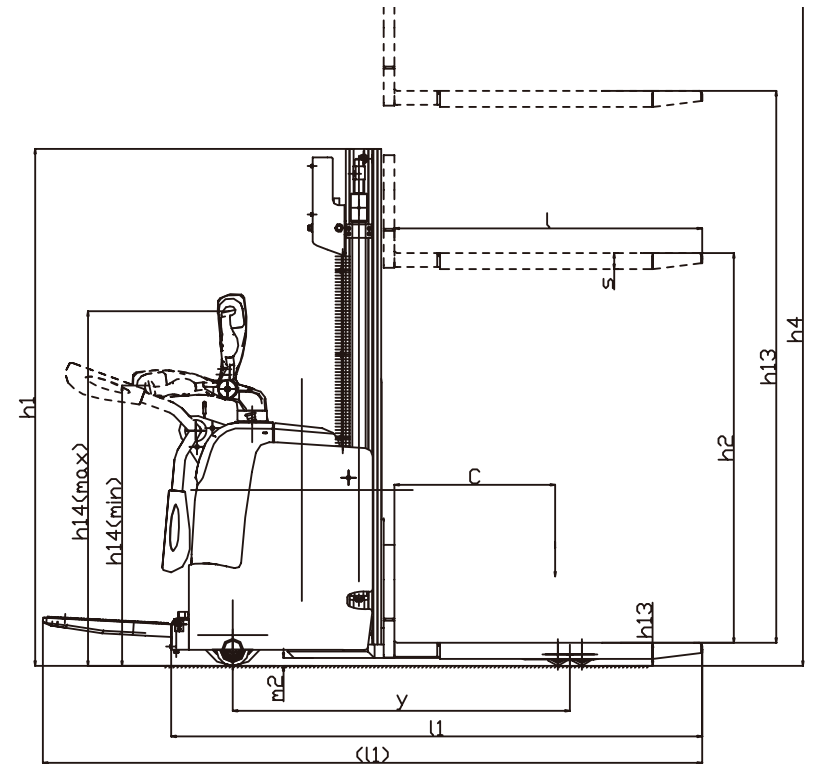



## Technical Specifications

Identification	Manufacturer		BYD
	Model		S14PS
	Load capacity	Q (kg)	1400
	Load center distance	C(mm)	600
	Axle centre to fork face	X(mm)	672
	Wheelbase	y(mm)	1260
Weight	Weight ,with/without load	kg	2600/1180
	Axle load with load, drive/load side	kg	1000/1600
	Axle load without load, drive/load side	kg	800/380
Wheel	Tyre, operator/load side		Polyurethane
	Tyre size, drive side		φ 230X82
	Tyre size, load side		4X φ 85X70
	Auxiliary wheel, size		2X φ 120X50
	Wheels number (x=driven), drive/load side		1X+1/4
	Track width, drive side	b10(mm)	520
	Track width, load side	b11(mm)	370
	Basic Dimensions	Height of mast, lowered	h1(mm)
Free lift		h2(mm)	136
Lift height		h3(mm)	3200
Height of mast, extended		h4(mm)	3717
Height of tiller arm in operation position, min./max.		h14(mm)	1040/1330
ork height, lowered		h13(mm)	90
Overall length		l1(mm)	1910/2450
Overall width		b1(mm)	800
Fork dimensions		s/e/l(mm)	60/180/1150
Width over forks		b5(mm)	560
Ground clearance, center of wheelbase		m2(mm)	≥ 25
Aisle width, 800x1200mm pallet lengthwise		Ast(mm)	2352
Aisle width, 1000x1200mm pallet lengthwise		Ast(mm)	2372
Turning radius (LH/RH)		Wa(mm)	1490/1970
Performance Data	Travel speed, with/without load	km/h	6/6
	Lift speed, with/without load	mm/s	180/240
	Lower speed, with/without load	mm/s	300/240
	Climbing ability, with/without load	%	5/10
	Stopping distance, with/without load	m	2.17/2.17
Drive	Drive motor output	kw	1.3
	Lift motor output	kw	3
	Battery voltage/capacity	V/Ah	24/130
	Battery weight	kg	70
Other	Sound level at driver's ear	dB (A)	75

## Working Environment

Temperature: -5 ~ 40° C

Working humidity: ≤ 90%

Operating Altitude: ≤ 2000m

Road: dry, hard, level and flat

Storage: in airy storehouse

Caution

If the working environment is harsh, decrease the goods or reduce the speed.

Dange

- (1) No sharp obstacle.
- (2) No strong acid or base on the road.
- (3) Do not soak the tire in the water for a long time.
- (4) Do not expose the truck to the burning sun.
- (5) No flammable gas, no flammable dust and no volatile flammable liquid.



Note

Contact with your BYD local dealer if the forklift is intended to be used in the following environments:

- (1) in places where explosives are stored
- (2) in dusty areas
- (3) in ports or water front with corrosive salt hazards
- (4) in chemical factories with acid and other chemical hazards
- (5) in potential explosive environments with dust or other explosive gas
- (6) in toxic environment
- (7) in radioactive environment
- (8) in other special environment

## NAMEPLATE AND DECALS

### Forklift nameplate

 <b>Electric Pallet Stacker</b>			
Model		Service weight	
Serial No.		Net weight (w/o battery)	
Rated capacity		Battery voltage	
Max.lift height		Battery capacity	
Battery weight(max.)		Battery weight(min.)	
 <b>BYD (SHAOGUAN) CO., LTD.</b>			
Add.: No.1, BYD Road, Zhenjiang Industrial Park, Shaoguan, Guangdong, China			

#### Note

- (1) The nameplate is placed on the left of the forklift.
- (2) After receiving the forklift, check the information on the nameplate and confirm if it complies with the one you've ordered.

#### Caution

- (1) Every forklift might have different specification. Check the nameplate before operation to confirm the forklift specification.
- (2) When transporting the load, it should not exceed the rated loading capacity of the forklift. Check and confirm the load of the forklift.

### Battery Nameplate

		铁电池/Iron-Phosphate Battery
产品使用环境 Operating Conditions	环境温度 Ambient Temperature	
	相对湿度 Relative Humidity	
产品基本性能 Basic Performance	型号 Model	
	电池型号 Cell Model	
	标准容量 Nominal Capacity	
	标称电压 Nominal Voltage	
	工作电压 Operating Voltage	
	额定工作电流 Rated Operating Current	
	电池包重量 Weight	
	出厂编号 Serial No.	
Caution: Before operation, you must be familiar with specific requirement for output configuration by referring to the instruction manual.		
  中国制造 Made in China		 <b>BYD (SHAOGUAN) CO., LTD.</b>

#### Note

- (1) The battery nameplate is placed on the battery.
- (2) After receiving the forklift, check the information on the nameplate and confirm if it complies with the one you've ordered.

### Loading Capacity Chart

When the lifting height exceeds, the loading capacity of the truck is reduced. The Loading capacity chart indicates the rated loading capacity the forklift has corresponding to the different lifting height.

Suppose the expected lifting height is 4300mm.

- (1) Draw the horizontal line at the coordinate of lifting height 4300 mm and find the crossing point of this horizontal line and the curve line of the loading capacity.
- (2) The ordinate on the X-axis of the crossing point reads 750kg, which is the rated lifting load.
- (3) If you want to increase the lifting height, decrease the weight of the cargo.

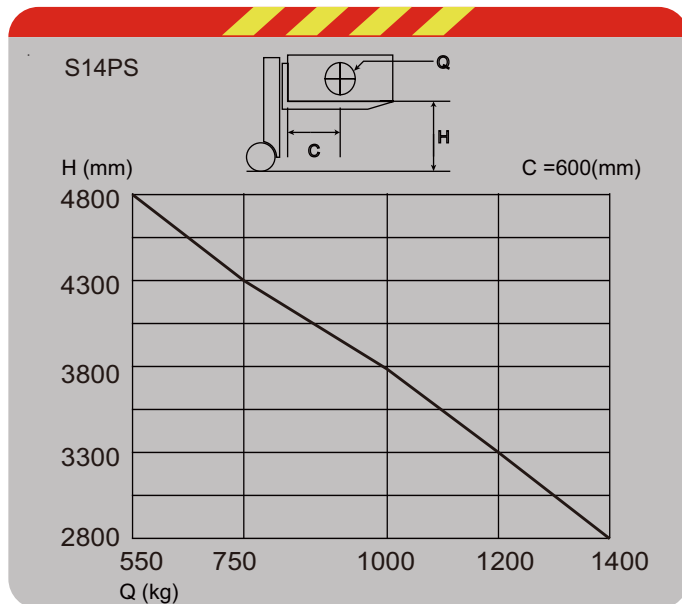

#### Caution

- (1) Forklift specification varies depending on customer requirements. Refer to the load capacity chart for confirmation on the maximum allowed load.
- (2) The load capacity chart reflects only compact, well palletized and evenly centered loads within the load limit. Otherwise the stability of the forklift and the rigidity of the related parts will be impaired.

#### Other decals

Please pay attention to notes or warning decals and signs before using.

## OPERATING

This chapter explains how to operate BYD electric forklift correctly.

# STARTUP AND CONTROL

## Key Switch

After the key is inserted into the key switch, Rotate the key clockwise to the start position and start the vehicle, and the key will automatically return to the on position. When the vehicle is powered on for a period of time, the vehicle will automatically power off; at this time, rotate the key to the start position to continue working.

Rotate the key anticlockwise to off position and take it out to turn off the forklift.

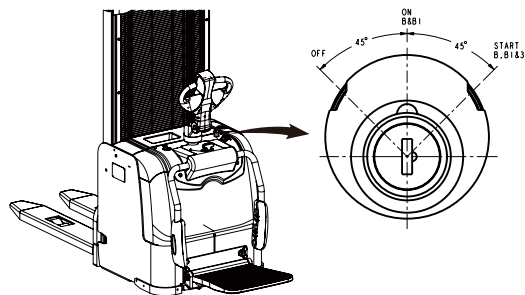

### Note

Before starting the forklift, pull up the emergency disconnect switch on the right side.

## Emergency Disconnect Switch

Press down the emergency disconnect switch to shut off the power. Rotate and pull up it to resume the power.

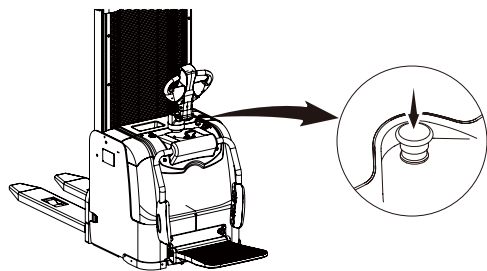

Fork carriage and pedal

Fork carriage

Before using the forklift, open the fork carriage to protect the operator during turning

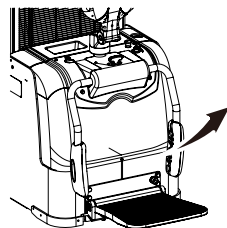

## Pedal

Open the pedal downward for use

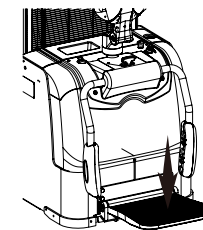

## Tiller



No.	Name	No.	Name	No.	Name
1	Lower Control Button	3	Horn Button	5	Direction Control
2	Lift Control Button	4	Emergency Reversal Switch	6	Low Speed Control

## Travel, Steering and Braking

### 1. Travel

Rotate the tiller to the area of A2. Rotate the direction control forward or backward to travel forward or backward.

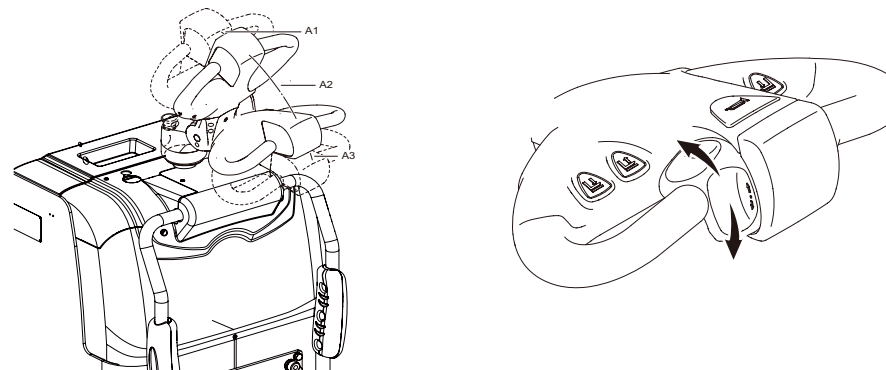

2. Steering

When travelling, turn the tiller right or left to steer.

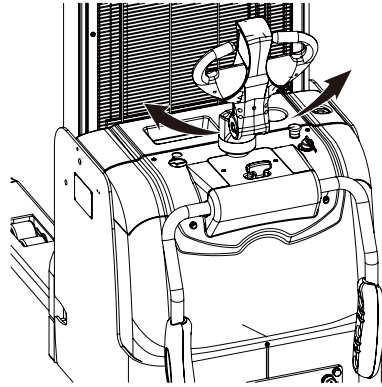

3. Braking

Rotate the tiller to the areas of A1 and A3 to brake; Release the accelerator button B to brake; when the vehicle speed is 0, apply the brake immediately.

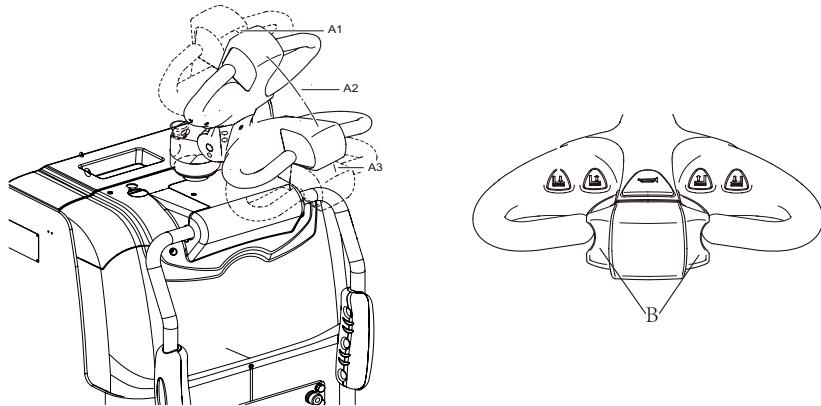

Low Speed Control

Press the low speed control below the tiller, and then the vehicle goes into low speed mode.



Fork Lifting and Lowering

Press the lift control button to lift the fork.

Press the lower control button to lower the fork.

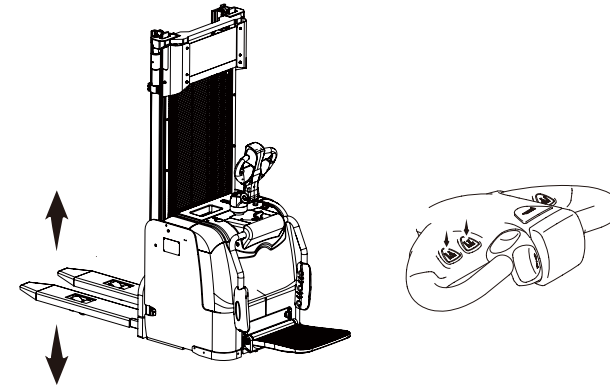

Horn

Press the horn button to send audible warning.

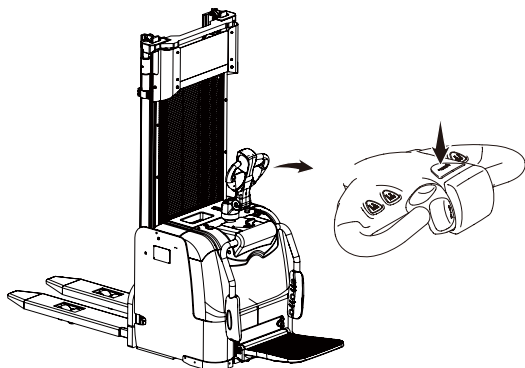

Emergency Reversal Switch

When the emergency reverse switch is struck, the vehicle will travel forward for some distance until it's not struck.

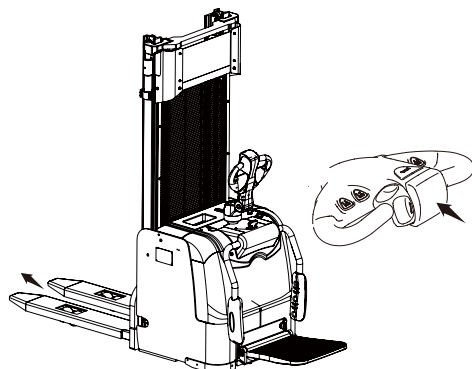

DISPLAY USING

Display (A type)

There is a screen and an indicator in the display. The screen shows the battery level, repairing sign, low speed sign, hour meter and fault code. The indicator light indicates low battery level or repairing.

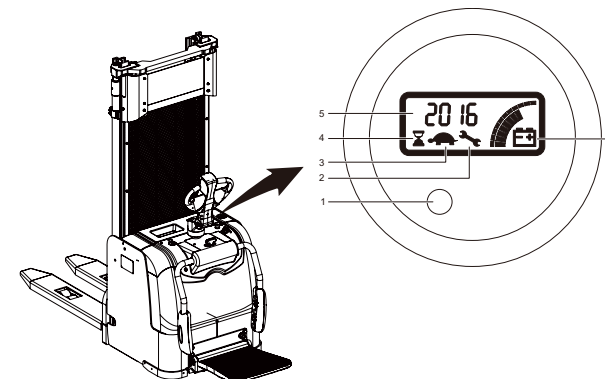

No.	Name	Descriptions
1	Warning Indicator	The indicator twinkles when the vehicle breaks down or the battery level is low.
2	Repairing Sign	The repairing sign appears when the vehicle breaks down.
3	Low Speed Sign	The low speed sign appears after the low speed control being pressed.
4	Hour Meter Sign	The hour meter sign appears after the vehicle being normally started.
5	Hours and Fault Code	The time worked appears after the vehicle being normally started. The fault code appears when the vehicle breaks down.
6	Battery state	The battery level is shown by ten notches, and each notch represent the 10% of the battery charge. The number of notches displayed by the battery varies with the actual battery level

Display (B type)

There is a screen and a light ring in the display (B type). The screen shows the battery level, hour meter and fault code. When a certain controller of the vehicle has fault, the light ring displays red, and the interface displays the current fault code.

No.	Name	Descriptions
1	Warning Indication	When the battery is low or the vehicle has fault, the light ring displays red, and the interface displays the current fault code.
2	Speed Display	It displays the current speed when the vehicle being normally started.
3	Working Hour Display	The time worked appears after the vehicle being normally started.
4	Battery state	Battery level is shown as a percentage

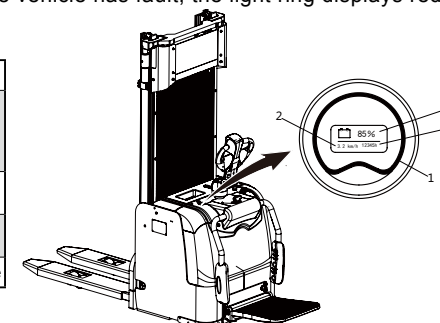

## TRANSPORTING LOADS

### Loading

#### 1. Load on the ground

- (1) Drive the forklift carefully up to the load and brake the forklift to a stop.
- (2) Lower the forks.
- (3) Insert the forks under the load.
- (4) Lift the forks.
- (5) When transporting, drive with caution, pay attention to the route condition and to the people ahead and maintain a proper driving speed. Transport the load to the designated place.

#### 2. Load on the high shelf

- (1) Drive the forklift carefully up to the load and brake the forklift to a stop.
- (2) Set the mast in the vertical position and raise the forks to the bottom of the load.
- (3) Insert the forks under the load.
- (4) Raise the load until it has left the shelf completely.
- (5) Reverse the forklift with caution at a low speed until the forklift leaves the stacking area.
- (6) Lower the forks.
- (7) When transporting, drive with caution, pay attention to the route condition and to the people ahead and maintain a proper driving speed. Transport the load to the designated place.

#### Danger

- (1) When approaching the load, do not travel at high speed to avoid crashing.
- (2) Do not stay beneath the raised load.

#### Caution

When transporting the load, the load should be securely fastened on a pallet with the gravity center well centered and proper stacking height. Do not damage the packaging of the goods and the handling personnel should bear the responsibility of safe loading.

### Travelling

- (1) When travelling with load, make sure that the load is well centered on the forks.
- (2) After the load is placed on the forks, keep the mast tilted backwards and raise the forks above the floor.
- (3) During the travelling of the forklift, do not tilt the mast forward or try raising the forks to avoid the danger of forklift nose over and losing stability.
- (4) If the stacked loads are high and affect the operator's visibility of the route ahead, operate the forklift in reverse except when the forklift is climbing the slope or inclines.

#### Warning

- (1) When driving the forklift on a slope, keep the forks always facing the uphill direction and downhill direction in contrast and drive in turtle speed mode.
- (2) Do not cross or turn around on a slope.

#### Caution

Have a second person as lookout if the visibility of the operator is reduced.

### Unloading

- (1) Drive the forklift carefully up to the stacking destination and decelerate when approaching.
- (2) Raise the forks to the proper height.
- (3) Drive the forks and load into the shelf.
- (4) Set the mast in the vertical position and lower the forks to the proper height until they get separated from the forks.
- (5) Slowly remove the forks from the bottom of the load.
- (6) After driving the forks out, start the next task.

### Exiting

- (1) Lower the forks after unloading.
- (2) Turn the key anticlockwise to OFF position and take it out.
- (3) Press down the emergency disconnect switch.
- (4) Exit.

## BATTERY

## Charging

Open the charging door cover, open the charging door, and then connect the charger connector. Follow the user manual of the charger to charge the forklift.

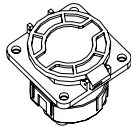
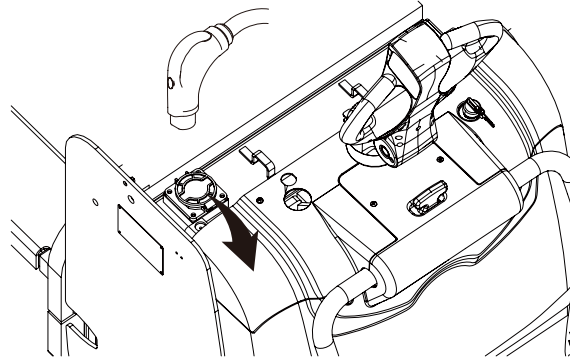

GB port

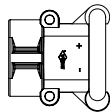

REMA port (Optional)

Note

- (1) If the charge port cover is opened, it is impossible to use the stacker. To use the stacker, close the charge port cover.
- (2) The environment temperature influences the charging time, it's suggested the forklift be charged at room temperature.

## TRANSPORTATION AND STORAGE

This chapter explains how to transport and store the forklift.



## LOADING, TRANSPORTATION AND UNLOADING

### Hoisting

- (1) Lowering the fork fully.
- (2) Hoist the truck by the hoisting hole on top side of the mast.

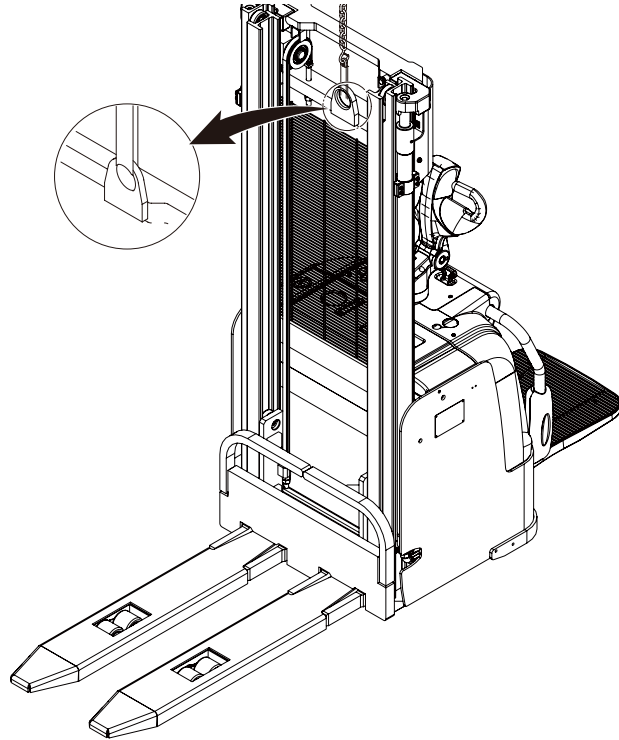

#### Danger

During the hoisting process, it must be ensured that no one is within the working range of the hoist.

#### Warning

Use only a hoisting equipment with sufficient loading capacity (Refer to the vehicle nameplate in detail for the weight of the vehicle).

### Driving into the Transport vehicle

Drive the forklift into the transport vehicle on turtle speed mode.

#### Caution

- (1) Have a supervisor or a second person on site as a lookout.
- (2) Make sure that the ground is strong enough to avoid the transport vehicle sinking into the floor.
- (3) Secure the transport vehicle with fixed block.
- (4) During loading and unloading, constantly check the rigidity and the stability of the ramp.

### Transporting and Unloading

- (1) Use a transport truck or a low flat bed truck to transport the forklift
- (2) Unloading the truck by hoisting follows the same procedure as the loading of the truck.
- (3) When driving the forklift out of the transport vehicle, reverse the forklift with caution at low speed. The rest of the procedure is the same as required for driving the forklift onto the transport vehicle.

## STORE AND RESTART

### Procedures of Store

Clean and remove the dust on the forklift components and conduct the following procedures:

- (1) Check forklift for any leakage and abnormal components. If yes, repair the forklift first.
- (2) Fully lift and lower the forks several times..
- (3) Lower the forks.
- (4) Spray a layer of lubricant over the parts left unpainted.
- (5) Check the hydraulic oil level and add if necessary.
- (6) Lubricate all the components..
- (7) Take off the key and make sure that forklift is disconnected from the battery power and press down the emergency disconnect switch. Battery status of charge should be around 50% to avoid over-discharge or full charge for long-term storage.
- (8) Use and operate the forklift for a while every month.

### Procedures to Restart

Clean and remove the dust on the forklift components and conduct the following procedures:

- (1) Lubricate all the components..
- (2) Fully lift and lower the forks and tilt masts several times.
- (3) Check the status of charge of the traction battery.
- (4) Check the hydraulic oil. Replace it if necessary.

#### Caution

The operator should repeatedly check the performance of the forklift brake when operating it for the first time after the forklift has been restored to service.

## MAINTENANCE

This chapter explains how to maintain the forklift.

## DAILY MAINTENANCE

### Period and Items

Daily (or every 8 hours) and weekly (or every 40 hours) for daily inspection items, whichever comes first. If the forklift works less than 8 hours per day, conduct the inspection and checks on a daily basis. If daily working hours exceed 8 hours, conduct the inspection and checks every 8 hours.

Inspection checklist:

No.	Item	1 day	1 week
		8 hours	40 hours
1	Exterior	Check	
2	Wheel	Clean and tighten	Clean and tighten
3	Mast	Check	
4	Hydraulic System	Check	
5	Display	Check	
6	Warning Equipments	Check	
7	Brake	Check	Check
8	Travel, Steering and Control	Check	
9	Connectors and Fuse	Check	
10	Clean	Clean	
11	Others	Check	

#### Caution

These inspections should be conducted before operating the forklift.

#### Note

Before conducting the daily inspection, recheck for any fault and fault found earlier.

### Content Description

#### 1. Exterior

- (1) Check the forklift body for damage and deformation.
- (2) Check the floor where the forklift is parked for oil leakage.
- (3) Check the condition of the nameplate and decals.
- (4) Check if any parts loose or fall off.

#### Note

If oil leakage occurs, confirm the location of the oil leakage and contact the BYD after sales service.

#### 2. Wheel

- (1) Check on a daily basis if the wheel fasteners are secured or loose. Fasten them if they are loose.
- (2) Take out debris embedded in the tire.
- (3) If the four tires are unevenly worn, or the tires are found damaged, or the rims are bent, then replace the wheels.

#### 3. Mast

- (1) Check the cylinders, oil pipes, and hoses for oil leakage.
- (2) Check the working equipment for deformation and damage. Check if the bolts are securely fastened.

#### 4. Hydraulic System

Check the hydraulic oil level in the oil tank

#### 5. Display

- (1) Check if the battery voltage and status of charger displayed are correct.
- (2) Check if any fault indicator appears on the display.

#### 6. Warning Equipments

- (1) Press horn to see if it works.
- (2) Check if other warning equipments work properly.

#### 7. Braking System

Move the handle to the braking zone while the forklift is travelling, to check whether the brakes operate efficiently.

#### 8. Travel, Steering and Control Inspection

- (1) Check for the operation of the tiller and abnormal sounds by rotating the tiller forward or backward and turning the tiller right or left.
- (2) Check for the operation of buttons.
- (3) Check the fasteners for looseness or missing.

9. Electric System Inspection

- (1) Check connectors and tighten the loose parts. Check electrical connectors for abnormality (for example, sign of burning).
- (2) Check fuses of main controller and replace them if necessary. Check whether the copper busbar of the main controller is burnt. If so, replace it.
- (3) Check whether low voltage fuse and relay work properly. Replace them if necessary.

Warning

Disconnect the battery before checking the electric system.

10. Clean

Clean the whole forklift with the compressed air.

11. Others

Check if there are others problems.

**REGULAR MAINTENANCE**

Period and Items

Period for regular inspection and maintenance, whichever comes first. For example, if the forklift works less than 250 hours in 6 weeks, conduct the following inspection and checks every 6 weeks, otherwise conduct the following inspection and checks every 250 hours. Perform the maintenance service accordingly

Category	Item	6 (weeks)	3	6	12	Months
		250	500	1000	2000	Hours
Chassis System	Gear Oil Level Checking	First Check		Check		
	Chains Adjustment	Adjustment				
Mast	Chains Lubrication	Lubrication				
	Mast Cleaning	Clean				
	Mast Clearance Adjustment	Adjustment				
	Hydraulic Oil Replacement	Replacement				
Hydraulic System	Oil Filter with Breather Filter	Replacement				
	Electric System Inspection	Check				
Others	Torque Inspection on Critical Fasteners	Check				

Note

If the working environment is harsh, the maintenance interval should be reduced, and advice from BYD after sales personnel should be sought.

Content Description

1. Chassis System

Check the gear oil level and add if necessary.

2. Mast

- (1) Check the tension the lift chains, adjust them if necessary.
- (2) Lubricate the chains
- (3) lean the mast.

3. Hydraulic System

- (1) Replace the hydraulic oil periodically.
- (2) Replace the oil filler with breather filler periodically.

4. Electric System

- (1) Check connectors and tighten the loose parts. Check electrical connectors for abnormality (for example, sign of burning).
- (2) Check fuses of main controller and replace them if necessary. Check whether the copper busbar of the main controller is burnt. If so, replace it.
- (3) Check if fuse and relay work properly and replace them if necessary.

Warning

Disconnect the battery before checking the electric system.

5. Others

Check torque on critical fasteners.

## CONSUMABLE ITEMS

### Type and Parameters of Consumable Items

Item	Consumable Items	Volume Needed	Type
Gear Oil Level Checking	Gear Oil	1.05 L	SAE 80W-90
Chains Lubrication	Machine Oil	As Needed	20#(Winter), 40#(Other Seasons)
Hydraulic Oil Replacement	Hydraulic Oil	9 L	ISO VG46, ISO VG68

Note

The given quantities are maximum values and take the actual quantities as the standard.

## BEFORE MAINTENANCE

### Before Maintenance

Before maintenance, place the vehicle on the sturdy and level ground, let the tiller on the initial position, turn off the vehicle, press the emergency switch button and block the vehicle.

### Emergency Lowering

If the fork can't be lowered by a fault of the vehicle loosen the pressure relief switch to lower the fork.

After lowering the fork, tighten the pressure relief switch.

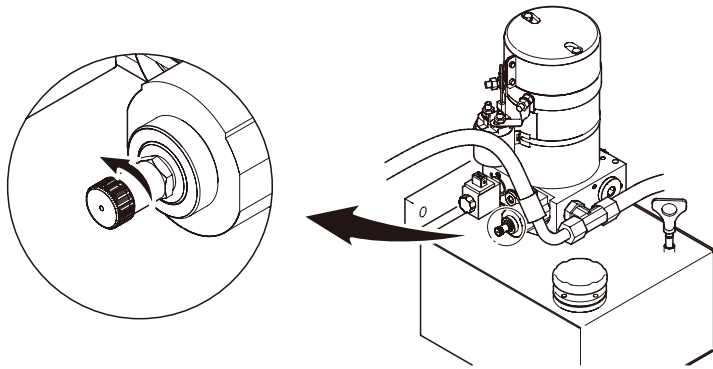

### Move the Vehicle with the Electric Fault

When the electric failure occurs, the electromagnetic brake stops the vehicle. Loosen screws and remove the brake, and then move the vehicle.

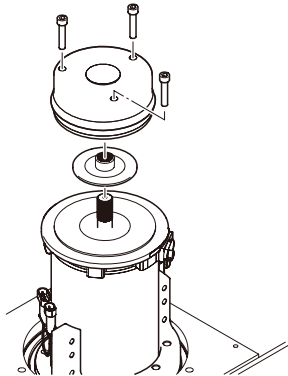

### Caution

- (1) Tow the vehicle by rigid connection only.
- (2) Tow the vehicle at low speed.

# CHASSIS SYSTEM MAINTENANCE

## Balance Inspection and Adjustment

If the abnormal shaking occurs, the vehicle balance is needed to adjusted. Remove the back cover, and then use the retainer to adjust the balance. Before adjustment, place the vehicle on the sturdy and level ground, and then loosen the mounting bolt of the castor wheel assembly.

- (1) When the front right side or the rear left side of the vehicle shakes, turn the retainer upward.
- (2) When the front left side or the rear right side of the vehicle shakes, turn the retainer downward.

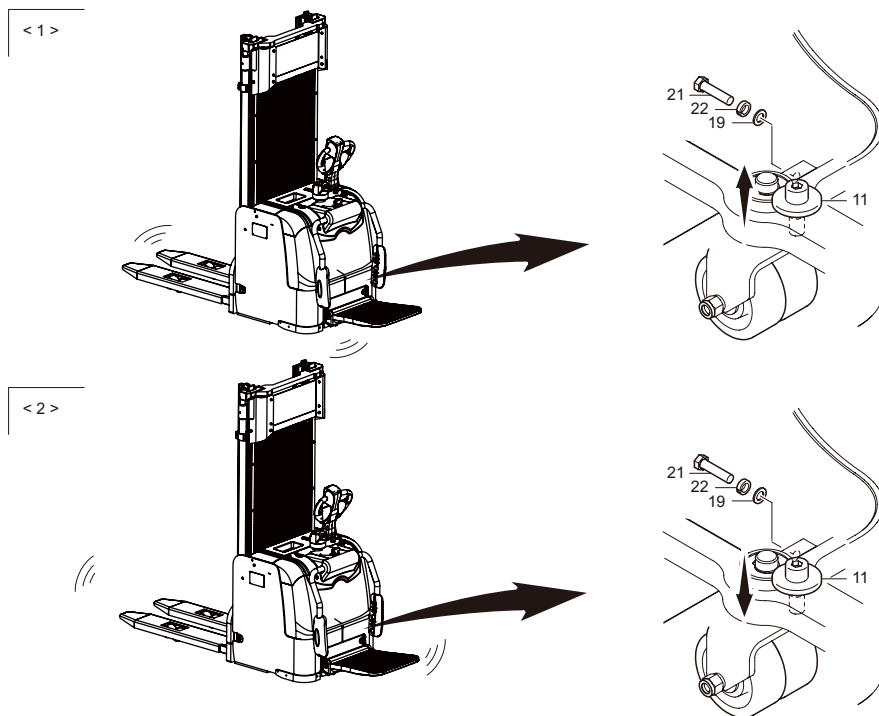

CODE	PART NAME	QTY	CODE	PART NAME	QTY
11	RETAINER	1	21	BOLT M12×45	1
19	WASHER M12	1	22	SPRING WASHER	1

## Load Wheel Replacement

- (1) Use the hoist equipment to raise the forks until the fork load wheel assembly can be rotated by 90 degrees, and then place the hardwood block under the forks.
- (2) Loosen the screw to replace one wheel, and then rotate the fork load wheel assembly by 180 degrees to replace the other wheel.
- (3) Use the same method to replace wheels on the other side.

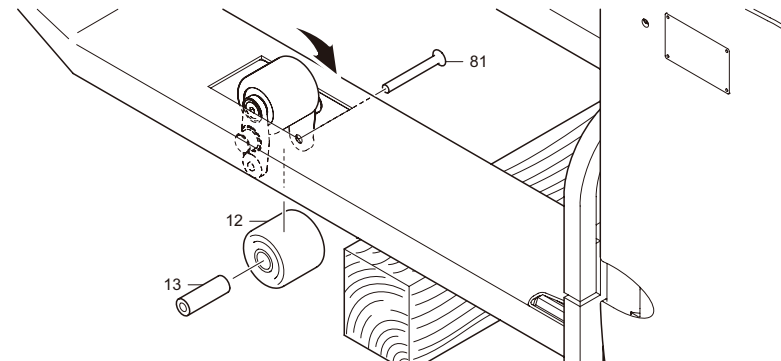

CODE	PART NAME	QTY	CODE	PART NAME	QTY
12	LOAD WHEEL	4	81	SCREW	4
13	BUSHING	4			

### Caution

- (1) All fork load wheels should be replaced as a set.
- (2) After replacement, the truck balance should be adjusted.

### Caster Wheel Replacement

- (1) Use the floor jack to raise the forklift, and then place the hardwood block under it. Loosen the bolt to take out the wheel assembly.
- (2) Loosen the nut and bolt to replace the wheel.

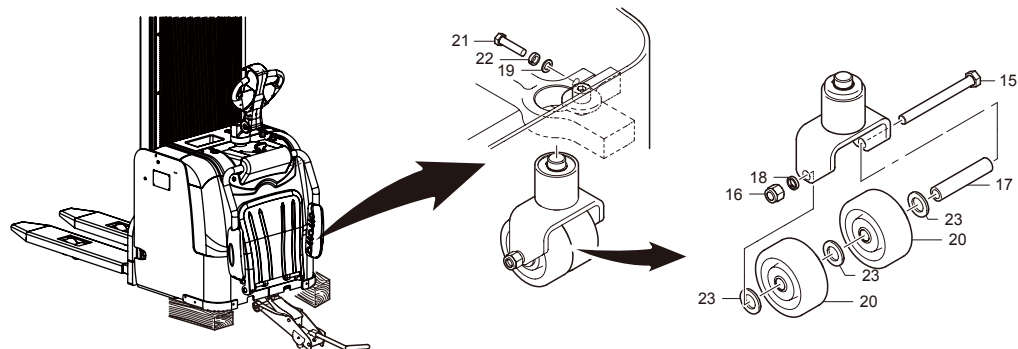

CODE	PART NAME	QTY		CODE	PART NAME	QTY	
15	BOLT M16×160	1		20	CASTOR WHEEL	2	
16	NUT M16	1	110 N-m	21	BOLT M12×45	1	90 N-m
17	BUSHING	1		22	SPRING WASHER	1	
18	SPRING WASHER M16	1		23	WASHER	3	
19	WASHER M12	1					

**Caution**

After replacement, the truck balance should be adjusted.

### Driving Wheel Replacement

Use the floor jack to raise the forklift, and then place the hardwood block under it. Loosen the nuts to replace the wheel.

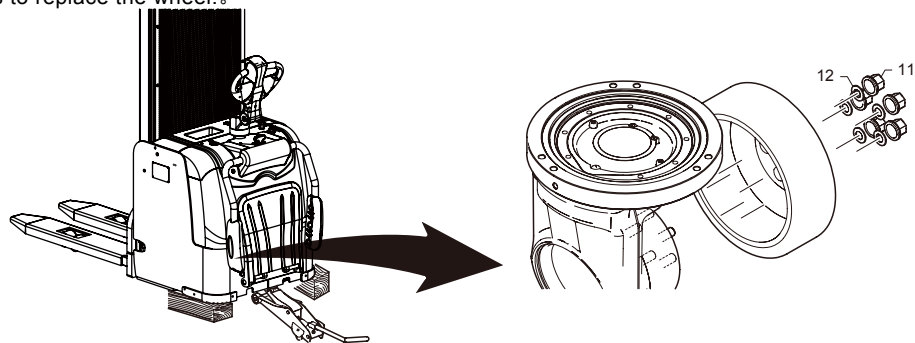

CODE	PART NAME	QTY	
11	NUT	5	90 N-m
12	SPRING WASHER	5	

**Caution**

After replacement, the truck balance should be adjusted.

### Gear Oil Level Checking

- (1) Clean the surrounding areas around the oil filler plug, and then unscrew it with the seal.
- (2) Check the oil level. The correct oil level and the correct oil quantity is achieved when the oil level is at the lower edge of the oil filler plug. Add gear oil if necessary.
- (3) After checking, screw in the oil filler plug with the sealing ring.

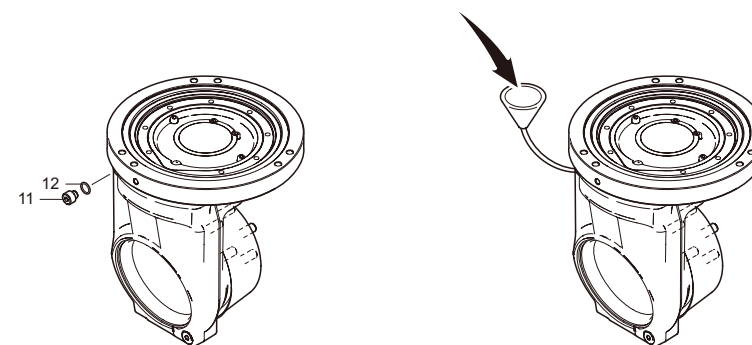

CODE	PART NAME	QTY	
11	OIL FILLER PLUG	1	30 N-m
12	SEALING RING	1	

**Caution**

- (1) While adding oil, be careful to prevent dust and water from entering the oil tank.
- (2) The oil level should be just at the lower edge of the oil filler hole.



### Gear Oil Replacement

- (1) Clean the surrounding areas around the oil filler plug and the oil drain plug, and place a suitable vessel under the oil.
- (2) Unscrew the oil filler plug and the oil drain plug with sealing rings.
- (3) After draining, screw in the oil drain plug with the sealing ring.
- (4) Add gear oil until the oil level is at the lower edge of the oil filler plug. Screw in the oil filler plug with the sealing ring.

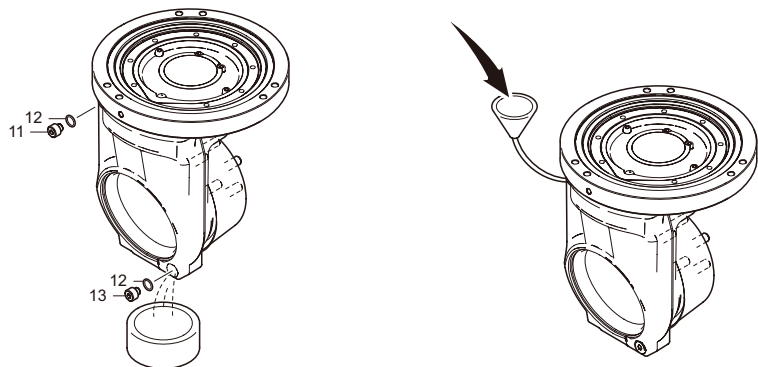

CODE	PART NAME	QTY		CODE	PART NAME	QTY	
11	OIL FILLER PLUG	1	30 N-m	13	OIL DRAIN PLUG	1	30 N-m
12	SEALING RING	2					

**Caution**

- (1) Oil drain time of approximate 5 minutes must not be exceeded.
- (2) When filling the oil, care about the condition around to prevent dust and water entering the oil tank.
- (3) When disposing the waste oil, keep people away and do not pour it into the sewer or onto the ground.
- (4) The oil level should be just at the lower edge of the oil filler hole.

### MAST MAINTENANCE

#### Chains Adjustment

The standard mast has the main lift chain that is needed to be adjusted, the free list mast has the main lift chain set and the free lift chain that are needed to be adjusted. Before adjustment, park the forklift on a level ground and fully lower the mast, switch off the forklift, take off the key and press down the emergency switch.

1. Standard Mast Lift Chain Adjustment

Loosen the upper and lower nuts of the lift chain, and then screw the middle nut to adjust the length of the chain. After adjustment, make the forks remain level and the chains remain the same tightness, and then tighten nuts.

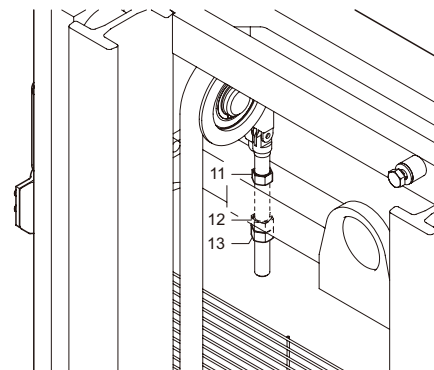

CODE	PART NAME	QTY		CODE	PART NAME	QTY	
11	NUT (UPPER)	1	110 N-m	13	NUT (LOWER)	1	110 N-m
12	NUT (MIDDLE)	1	110 N-m				

**Caution**

After adjustment, make sure that the chains aren't slack when the lift cylinder is in the original position.

2. Free Lift Mast Lift Chain Adjustment

- (1) Loosen the upper and lower nuts of the lift chain, and then screw the middle nut to adjust the length of the chain. After adjustment, make the chains remain the same tightness, and them tighten nuts.

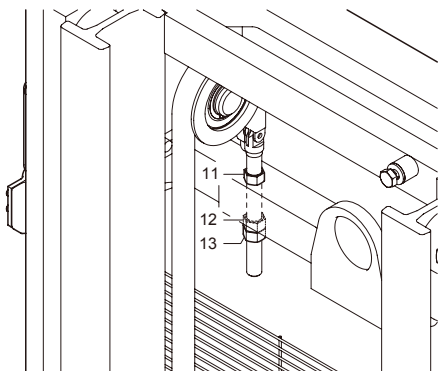

CODE	PART NAME	QTY		CODE	PART NAME	QTY	
11	NUT (UPPER)	1	110 N-m	13	NUT (LOWER)	1	110 N-m
12	NUT (MIDDLE)	1	110 N-m				

- (2) Loosen the upper and lower nuts of the free lift chain, and then screw the middle nut to adjust the length of the chain. After adjustment, make the forks remain level and the chains remain the same tightness, and them tighten nuts..

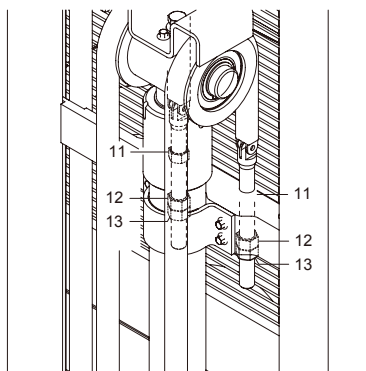

CODE	PART NAME	QTY		CODE	PART NAME	QTY	
11	NUT (UPPER)	1	110 N-m	13	NUT (LOWER)	1	110 N-m
12	NUT (MIDDLE)	1	110 N-m				

Chains Lubrication

- (1) Clean the exterior of the lift chain and remove dust and debris.
- (2) Add the machine oil and let it penetrate the chain joint.
- (3) After lubrication, lift and lower the mast several times.

Mast Cleaning

Take out debris between the roller and the channel of the mast.

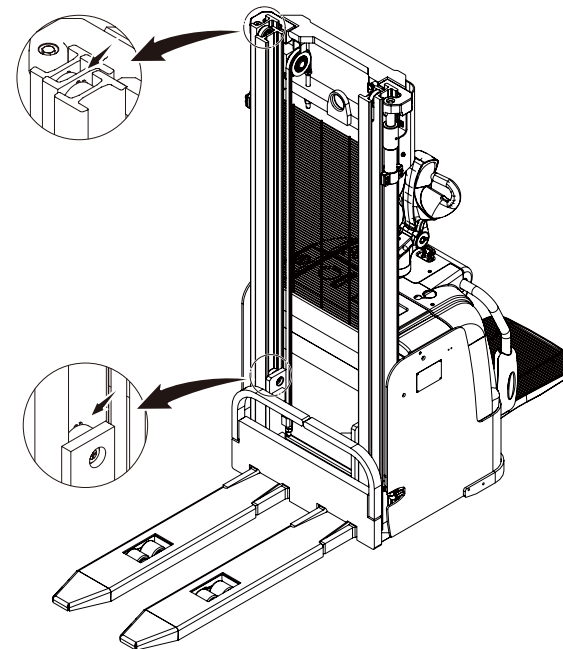

Mast Clearance Adjustment

1. General Description

A circlip locks the mast roller, bearing, and the dust protection that are installed on the mast or the carriage stub. The bearing is used to adjust the clearance of the mast and carriage by the

adjusting screw, which is installed on the other side of the stub. Adjusting screw is secured by a secure pin.

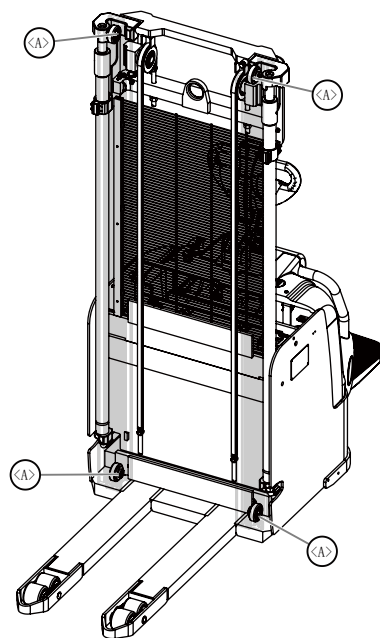
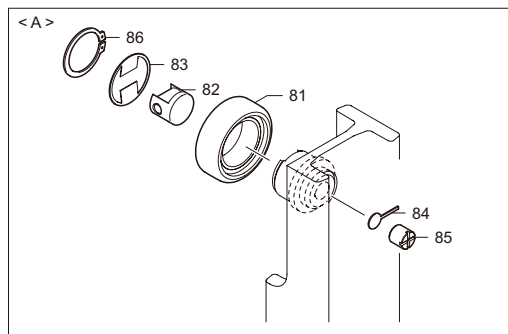

CODE	PART NAME	QTY	INFORMATION	CODE	PART NAME	QTY	INFORMATION
81	MAST ROLLER	4		84	SECURE PIN	4	110 N-m
82	BEARING	4		85	ADJUSTING SCREW	4	
83	DUST PROTECTION	4		86	CIRCLIP	4	

2. General Carriage and Mast Clearance Adjustment Procedure

- (1) Lift the mast to expose the position of the adjusting screw.
- (2) Bend the secure pin to expose the adjusting screw.
- (3) Use the screw to adjust the clearance.
- (4) After adjustment, bend the secure pin to secure the adjustment screw.

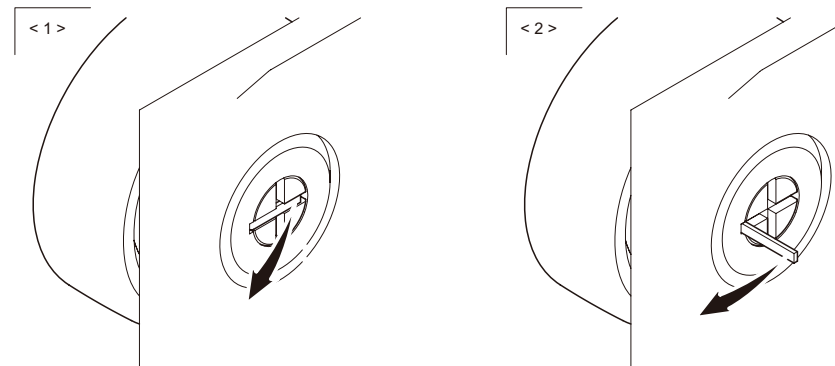

3. Adjustment Order

Order of adjusting 2-stage mast and carriage clearance:

- (1) Clearance between the outer mast and the inner mast.
- (2) Clearance between the inner mast and the carriage.

Order of adjusting 3-stage mast and carriage clearance:

- (3) Clearance between the outer mast and the middle mast
- (4) Clearance between the middle mast and the inner mast.
- (5) Clearance between the inner mast and the carriage.

## HYDRAULIC SYSTEM MAINTENANCE

### Hydraulic Oil Filling

- (1) Pull out the oil dipstick, use the clean cloth to wipe the oil on it, and then insert it back.
- (2) Pull out the oil dipstick again, and then see if the oil level is between two marks.
- (3) If the oil level is under the lower mark, take of the oil filter cap and refill the oil.

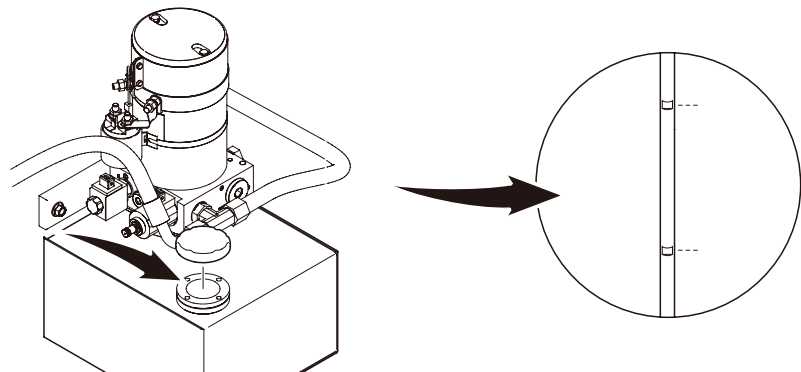

#### Caution

- (1) While adding oil, be careful to prevent dust and water from entering the oil tank.
- (2) Do not mix different types of hydraulic oil.
- (3) When disposing the waste oil, keep children away and do not pour it into the sewer or onto the ground.
- (4) Using unauthorized hydraulic oil might cause damage to hydraulic system. Use only authorized hydraulic oil. If you need to switch to other types of hydraulic oils, contact with the BYD forklift after sales service people.

### Hydraulic Oil Replacement

- (1) Disconnect the electric line and the pressure hose from the hydraulic unit, and remove it after loosening the bolts.
- (2) Remove the hydraulic unit, drain the oil in the oil tank, and then refill the oil.

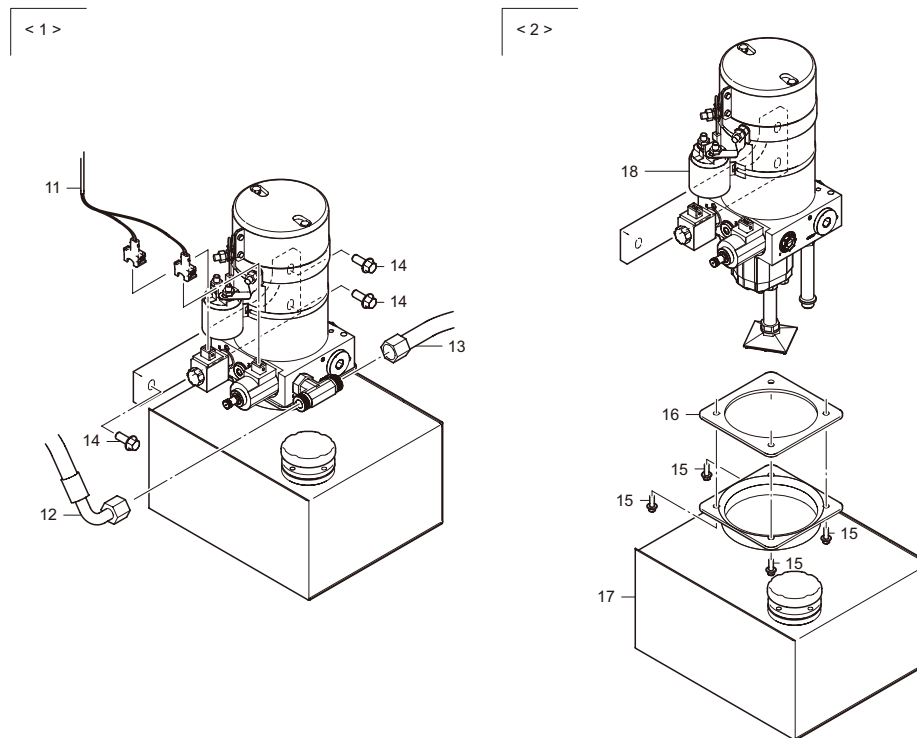

CODE	PART NAME	QTY	CODE	PART NAME	QTY
11	DATALINE	1	15	BOLT	4
12	PRESSURE HOSE	1	16	RUBBER SEAL	1
13	PRESSURE HOSE	1	17	OIL TANK	1
14	BOLT	3	18	HYDRAULIC UNIT	1

Caution

- (1) While adding oil, be careful to prevent dust and water from entering the oil tank.
- (2) Do not mix different types of hydraulic oil.
- (3) When disposing the waste oil, keep people away and do not pour it into the sewer or onto the ground.
- (4) Using unauthorized hydraulic oil might cause damage to hydraulic system. Use only authorized hydraulic oil. If you need to switch to other types of hydraulic oils, contact with the BYD forklift after sales service people.

## ELECTRIC SYSTEM MAINTENANCE

Warning

Disconnect the battery before checking the electric system.

### Electrical Wiring Inspection

- (1) Check connectors and tighten the loose parts.
- (2) Check electrical connectors for abnormality (for example, sign of burning).
- (3) Check the connection jackets for looseness. Reinstall them if loose.

### Main Controller Inspection

Check connectors of main controller and tighten the loose parts. Check fuses of main controller and replace them if necessary. Check whether the copper bar of the main controller is burnt. If so, replace it.

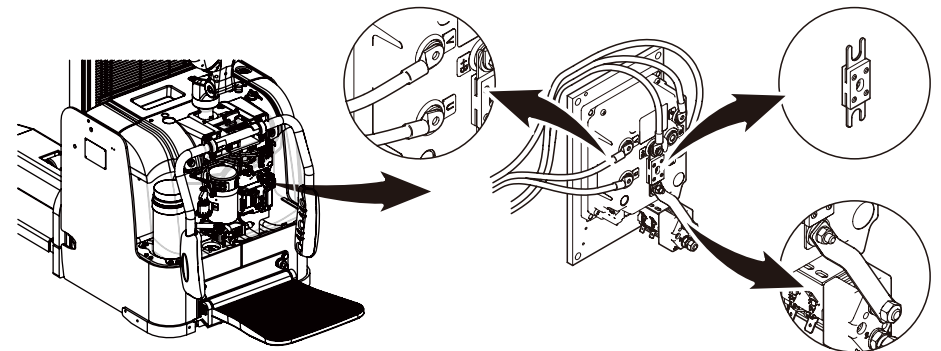

Low Voltage Fuse and Relay Inspection

Check whether low voltage fuse and relay work properly. Replace them if necessary.

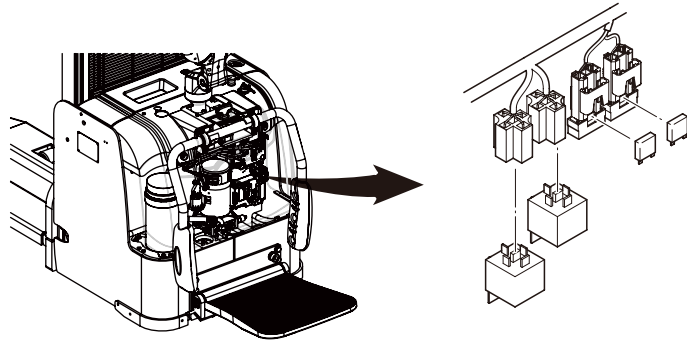

TORQUE INSPECTION ON CRITICAL FASTENERS

Torque Inspection on Wheel Fasteners

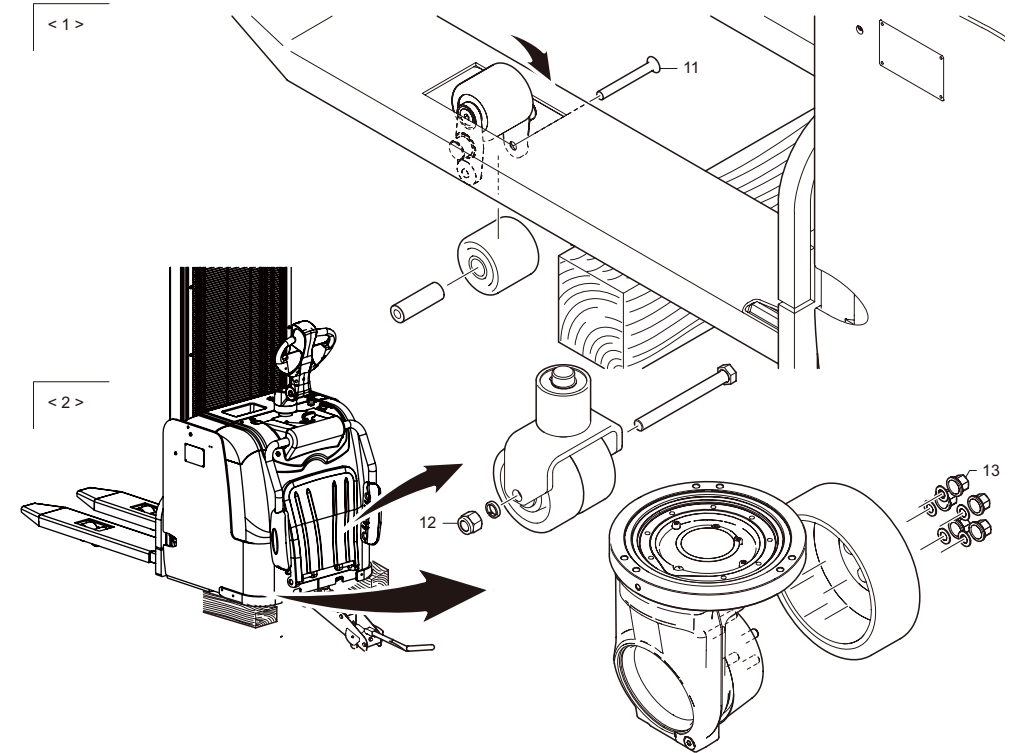

CODE	PART NAME	QTY		CODE	PART NAME	QTY	
11	LOAD WHEEL SCREW	4	90 N-m	13	DRIVE WHEEL NUT	1	90 N-m
12	CASTOR WHEEL NUT	2	110 N-m				

Mast Fasteners Torque Checking

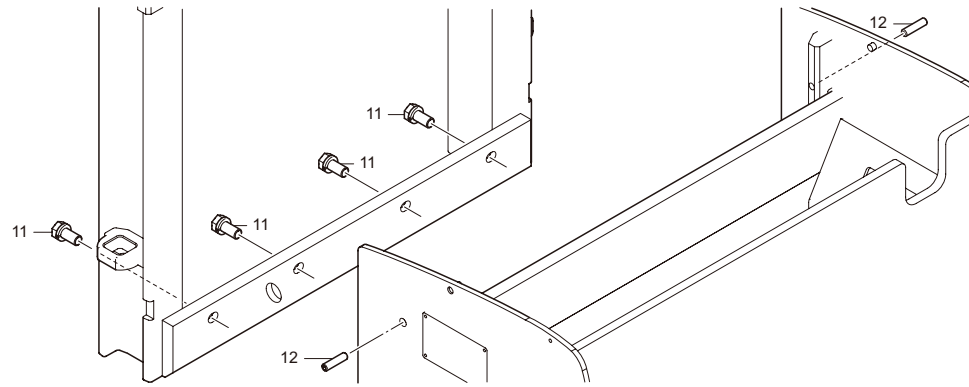

CODE	PART NAME	QTY	TORQUE
11	BOLT	4	100 N-m
12	SCREW	2	30 N-m

SCHEMATICS

Hydraulic Schematic

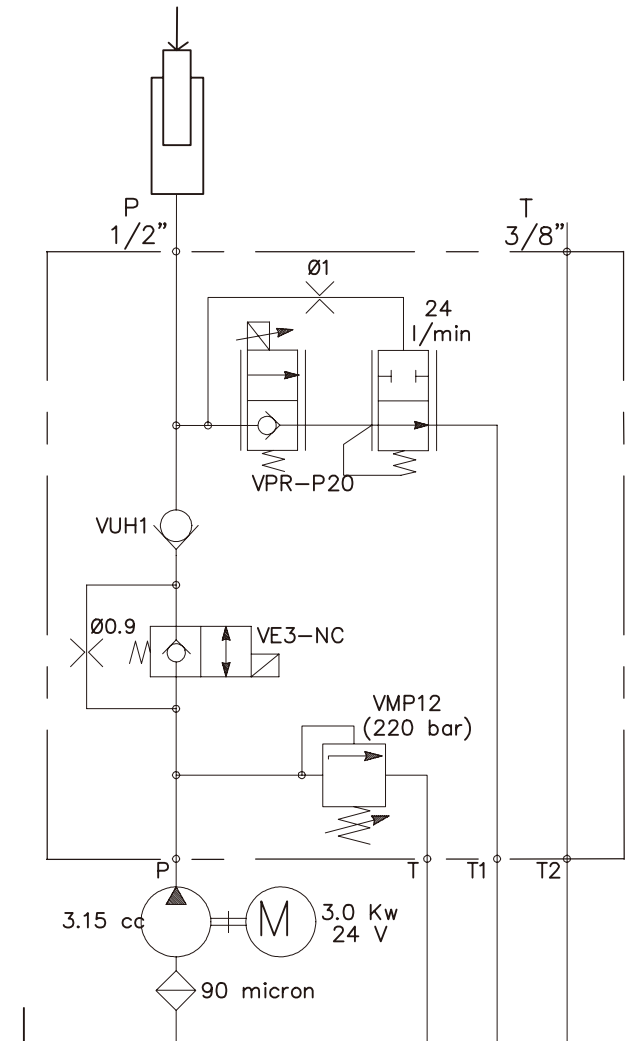

Schematic of Electrical System

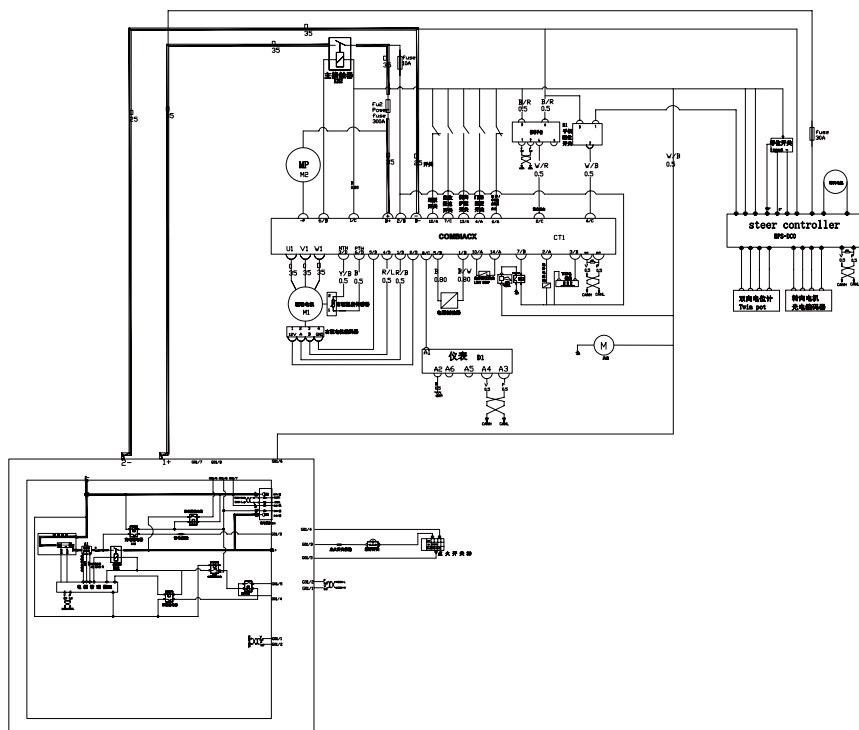

Fault Code Table

Display	ALARM	Fault name	Recommended inspection
02A00	BATTERY LOW	Battery level low	If the parameter "BATTERY CHECK" is not set to zero, no LED representing battery state-of-charge will come on when battery state-of-charge is less than 15%. The warning will be displayed and the lift function of the forklift will be disabled. In this case, it is imperative to charge the battery. If the battery is operational, check whether the controller parameter "ADJUST BATTERY" agrees with the battery voltage.
	EPS RELE OPEN	EPS relay open	Battery charging Check whether the EPS controller has fault
	DATA ACQUISITION	Data collection	Activation of this fault indicates data acquisition is under way. Wait data acquisition is completed. Do not operate during data collection and restart after completing
	CHECK UP NEEDED	Maintenance interval	Maintenance interval is expired. Maintenance is required. Change CHECK UP DONE to ON, turn off and restart
02A01	WRONG CONFIG	Wrong configuration	Clear EEPROM
02A08	WATCHDOG	Watchdog fault	Turn the key switch to "START" , to see whether the watchdog circuit is activated before the software is run. In the standby or operation state, the watchdog signal is invalid (alarm state). Fault analysis: The watchdog hardware circuit or microcontroller output section is damaged. Neither of the two cases is associated with external components. Replace the controller.
	FLASH CHECKSUM	Flash memory fault	With the key switch turned to "ON" , the value stored in the flash memory by the program should be a positive value. This fault will be reported in the case of a negative value. Fault analysis: The flash memory of the microcontroller could become faulty. The flash memory, or the program stored could be damaged. Attempt to configure the program of the logic card again. If the fault is still there, it exists in the microcontroller. Replace the controller.
	WATCHDOG#2	Watchdog fault 2	Possible cause: During startup of the forklift, the watchdog circuit has been activated before the software is initiated. In the standby or operation state, the watchdog signal is invalid (alarm state). Fault analysis: The watchdog hardware circuit or microcontroller output section is damaged. Neither of the two cases is associated with external components. Replace the controller.
02A10	WRONG RAM	Fault with the dynamic memory	The fault is detected when the main memory is tested. Registered address is "DIRTY" . This fault can limit the operability of the forklift. Fault analysis: Turn the key switch to "OFF" , then to "ON" . If the fault still exists, replace the controller.
02A11	STALL ROTOR	Motor stalling	1.Motor stops running.2.Motor encoder fault3.Damaged harness or incorrect wiring connection.4.Problem with power supply to the encoder.
02A13	EEPROM KO	EEPROM error	1. Restart the key switch, if the fault still exists, please replace the controller; 2. Restart the key switch, if the fault disappears, please reset the parameter.
	PARAM RESTORE	Parameter restore	Perform CLEAR EEPROM operation. If the fault disappears, change the parameters one by one to the set value. If the fault does not disappear, replace the controller., If the CLEAR EEPROM operation has been performed, the fault prompt parameter is restored to the default; if there is no CLEAR EEPROM, there is a fault inside the controller.
02A16	AUXOUTPUT KO	Electromagnetic brake coil fault	Check the electromagnetic brake coil for abnormality. If not, replace the controller
02A17	LOGIC FAILURE #3	Logic fault #3	Sudden disconnection during working of coil output line./ Fault with the current protection function of logic card The controller should be replaced.
02A18	LOGIC FAILURE #2	Logic fault #2	1. Check the motor power circuit for problems, including the fuse of controller; 2. Check the parameter table; 3. If there is no problem with the above two items, replace the controller.
02A19	LOGIC FAILURE #1	Logic fault #1	1. Test the battery voltage; 2. Check if the ADJUST BATTERY in the controller matches the actual battery voltage.
02A20	HEIGHT SENS OPEN		
02A21	CHARGE SAFETY	Charge safety	This fault can be reported if the forklift is operated while the battery is being charged. This prevents anyone from operating the forklift while the battery is being charged.
	HEIGHT SENS LOCK		
	reset cutback 1		
02A26	CURRENT SENS. KO		
02A27	PHASE KO	Open circuit of U/V/W phase	Check whether U/V/W phase is correctly connected.



Display	ALARM	Fault name	Recommended inspection
02A28	PUMP VMN LOW	Oil pump VMN low	Possible cause: When the motor is turned on, the low-end voltage of MOS tube is higher than 10% the normal battery voltage, or the phase voltage is higher than 50% the battery voltage. Possible causes: 1.Incorrect phase connection or faulty circuit of the motor. Check the motor for incorrect phase connection. Check the motor for current leakage to the ground. Check the motor for broken coil. 2.Replace the controller.
02A29	PUMP VMN HIGH	Oil pump VMN high	Possible cause: When the motor is turned on, the low-end voltage of MOS tube is higher than 10% the normal battery voltage, or the phase voltage is higher than 50% the battery voltage. Possible causes: 1.Incorrect phase connection or faulty circuit of the motor. Check the motor for incorrect phase connection. Check the motor for current leakage to the ground. Check the motor for broken coil. 2.Replace the controller
02A30	vmn low	3 phase wire fault	Check the 3 phase wire of motor
02A31	vmn high	VMN high	Possible cause: When the motor is turned on, the low-end voltage of MOS tube is higher than 10% the normal battery voltage, or the phase voltage is higher than 50% the battery voltage. Possible causes: 1. Incorrect phase connection or faulty circuit of the motor. Check the motor for incorrect phase connection. Check the motor for current leakage to the ground. Check the motor for broken coil. 2. Replace the controller.
02A32	PUMP VMN NOT OK		
02A37	contactor closed	Main contactor get stuck	Check whether the main contactor get stuck
02A38	contactor open	Main contactor open	1. Broken circuit of main contactor coil. 2. Main contactor damaged
02A40	AUX DRIV.SHRT.	Short circuit of auxiliary drive	Short circuit of drive circuit of electromagnetic brake or auxiliary electric brake.Check for short circuit or low-impedance push-pull output between A16 and -BATT. Fault with drive circuit of logic card. Replace the controller.
02A41	W R O N G BATTERY	Fault with battery setting	While the forklift is being started, the controller checks whether battery voltage is within the nominal voltage range. 1. Check whether the "BATTERY VOLTAGE" setting in the "TESTER" agrees with the indication of the voltmeter. In the case of disagreement, change battery voltage setting to be the same as the measured value, by using the "ADJUST BATTERY) function. 2. Replace the battery.
02A42	AUX DRIV.OPEN	NFault with drive of auxiliary output)	Drive circuit of auxiliary coil is unable to drive the load. Device itself or drive coil is damaged. Replace the controller.
02A47	EVP2 NOT OK	NAUX2 input voltage is outside the range	Check whether NAUX2 input voltage is within the range. If not, recalibrate the maximum and minimum of NAUX2, and turn the key switch to "ON" again. This fault will disappear;
02A48	EVP1 NOT OK	NAUX1 input voltage is outside the range/ (CAD fault table: Open circuit of proportional valve drive circuit)	Check whether NAUX1 input voltage is within the range. If not, recalibrate the maximum and minimum of NAUX1, and turn the key switch to "ON" again. This fault will disappear.
02A49	LIFT + LOWER	Faults with lifting and lowering exist at the same time	1. Improper operation; 2. Self fault of lift and lowering switch; 3. Replace the controller;
	i=0 ever	Drive current cannot be stopped	If the connection of motor 3 phase wire has no problem, please replace the controller
02A50	EVP1 COIL OPEN	Open circuit of NAUX1 coil	Check NAUX1 coil for open circuit, and whether EVP1 type setting is correct.
02A51	EVP2 COIL OPEN	Open circuit of NAUX2 coil	Check NAUX2 coil for open circuit, and whether EVP2 type setting is correct.
	TILLER OPEN	Tiller input switch is disconnected	With the triller input switch disconnected, after a period approximately 30s has elapsed, the main contactor will disengage and the warning will occur. The warning will not occur next time the forklift is operated.

Display	ALARM	Fault name	Recommended inspection
02A52	PUMP I=0 EVER	Oil pump I=0 fault	Check whether the power supply line of the oil pump motor is in good condition. If the line is in good condition, replace the controller;
02A53	STBY I HIGH	Standby current is high	The micro controller system has detected that the signal of the current sensor is outside the permissible range of current with the forklift in the idling state. This fault is irrelevant to external components. Replace the controller.
	WRONG ZERO	Error of zero voltage	While the forklift is being started, feedback value of high end voltage of VMN is not in the order of 2.5V. Circuit of the controller is damaged.Fault analysis: The following checks are recommended.Check internal connection of the motorCheck power cable connection of the motor.Check for drain current between the motor and the forklift housing.If the motor connection is in good condition, the fault is in the controller interior. Replace the controller.
02A54	LOGIC FAILURE #1	Logic card fault #1	Faults caused by under-voltage or over-voltage protection. In 24V system, the controller detects a voltage above 45V or below 9V; In 48V system, the controller detects a voltage above 65V or below 11V. Possible causes: 1. Whether there is short circuit in the circuit system, such as DC-DC, brake coil, etc., or whether the controller input power supply is in good contact. 2.Whether the battery voltage is over low or over high. 3.Check if the power cable above the terminals such as B+, B, main contactor is tight. 4.Whether the calibration parameter of controller voltage is consistent with the actual voltage. 5.Fault with the hardware circuit protected by over-voltage on the logic card. Replace the controller.
02A55	LOGIC FAILURE #2	Logic card fault #2	Fault with the phase voltage feedback hardware circuit in the logic card. Replace the controller.
02A56	PUMP I NO ZERO	Current exceeds limit while pump motor does not run	Replace the controller;
02A60	CAPACITOR CHARGE	Capacitor charging error	With the key switch turned to "ON" , the controller will charge the capacitor via the power resistor. The controller will detect whether the capacitor is fully charged within the specified time. If the capacitor is not fully charged within the specified time, and the capacitor voltage is still less than 20% the battery voltage, the controller will display the warning and the main contactor will not engage.
02A61	THERMIC SENS. KO	Temperature sensor fault	Controller temperature sensor output signal is outside the range. This fault is not related to external components. Replace the controller.
	high temperature	Controller overheating	Measure the temperature of controller base plate.
02A62	TH.PROTECTION	Controller over-temperature protection	Lower the controller temperature to below 85oC. If the fault still exists, possibly the temperature sensor or controller becomes faulty. Replace the controller.
02A64	TILLER ERROR	Interlock mismatches H&S input	Replace the controller;
02A65	MOTOR TEMPERAT.	Motor temperature high	1. If the motor temperature digital switch is turned on, or analogue signal exceeds the cutout value, then the fault results. 2. When motor temperature rises to 120 ° C, the controller will display the warning. The forklift still can travel but the maximum current is reduced with the forklift performance degraded. When the motor temperature reaches 125 ° C, the motor stops working. In this case, action shall be taken to cool the motor. 3. The fault still exists when the motor cools, check the line. If all have no faults, replace the controller.
02A67	SENS MOT TEMP KO	Temperature sensor fault	Symptom: Output signal of motor temperature sensor is outside the permissible range. Solution: Check the signal value and connection of the sensor. If they are normal, the fault occurred in the controller.
	NO CAN MSG.	No CAN signal	Fault with CAN communication between steering and towing. Check CAN connection, as well as version and configuration of software.

Display	ALARM	Fault name	Recommended inspection
02A68	SMARTDRIVER KO	Drive of electromagnetic brake fault	Check whether the high end (CNB#1) of the drive of electromagnetic brake is short circuited to the terminal B-. If not, the internal drive module could be damaged.
	WAITING FOR NODE	Waiting for signal from a node	In the CAN communication network, a certain controller has received the signal that another controller cannot communicate normally. The said certain controller hence remains waiting until the whole CAN communication network reverts to normality. Check the controller that cannot communicate normally for failed connection. Check whether the software version or parameter settings are correct.
02A70	encoder error	Encoder fault	Check the motor encoder
	EPS RELAY OPEN	EPS relay open	Check whether the EPS controller has fault
02A71	EEPROM KO	Memory is damaged	Forklift does not travel. Parameter storage becomes faulty so that forklift stops operation. Operate the key switch for several times. If the fault still exists, replace the logic card. If the fault disappears, parameters previously stored have been replaced by wrong parameters. It is imperative to set the parameters again.
	HANDBRAKE handbrake		
02A72	VMN LOW	VMN low	Cause: When the motor is turned on, the high-end voltage of MOS tube is less than 66% the capacitor voltage, or when the motor is running, the high-end voltage of MOS tube is less than the requirement. Possible causes: 1.Incorrect phase connection or faulty circuit of the motor. Check the motor for incorrect phase connection. Check the motor for current leakage to the ground. Check the motor for broken coil.2.Check whether the main contactor engages securely. Check the contacts for wear. 3.Replace the controller.
02A73	sens.Motor temp.ko	Motor temperature sensor error	Check harness of motor temperature sensor.
02A74	DRIVER SHORTED	Short circuit of contactor	Check whether there is short circuit in the coil output from the controller. If not, replace the controller
	AUX BATT.SHORT.	Fault with auxiliary drive voltage	Check whether BI is correctly connected to B5. If so, replace the controller;
	DRV.SHOR.EV	Short circuit of EV cable	Check whether the low end of EV1/EV2/EV3 is short circuited to B-. If not, it is required to replace the controller;
02A75	C O N T A C T O R CLOSED	Contacts of contactor get stuck	Before energizing the coil of main contactor, the controller will check whether the contacts of main contactor get stuck. Attempt to discharge the capacitor. If the capacitor voltage is reduced by 20% the battery voltage, the fault could exist. 1. Check whether the contacts of the contactor get stuck. If so, replace the contactor.
	CONTACTOR DRIV- ER	Short circuit of drive	With the key switch turned to "ON", the microprocessor will check the drive of main contactor for short circuit. In case of short circuit, the warning will be displayed. Check whether the positive terminal of coil of main contactor is short circuited to A16 or negative terminal of power supply. If externality is normal, replace the controller.
	CONT.DRV.EV	EV drive of the controller is inoperable	Replace the controller;
02A76	KEY OFF SHORTED	Short circuit of the key switch	In the startup phase, if the controller detects a low logic level when the key switch is turned to "OFF", this fault will be displayed. Fault analysis: A highly possible cause is voltage being too low. Perform the following checks. -Key switch based external load (for example, turning on the DC-DC converter. Relay or contactor switch input signal lower than startup voltage).-Check the connections of the power supply cables to the positive and negative terminals of the battery, and to the terminals -BATT and + BATT terminals of the main contactor and controller. The screws shall be tightened to torque 13Nm to 15Nm.-If no voltage drop in the power supply circuit is detected, this fault will be reported each time the key switch is turned to "ON". The hardware of controller could become faulty. It is necessary to replace the controller.
	COIL SHOR.MC-EB	Main contactor or elec-tromagnetic brake is heavily loaded	1. Check whether the output and load of the controller are excessive; 2. Replace the controller;
	COIL SHOR.EV.	PEV coil fault	Fault with the PEV drive coil. Check whether the PEV drive coil connection or the coil itself are in good conditions;
	coil shorted	Short circuit of coil	Check whether there is short circuit of main contactor coil and oil pump contactor coil

Display	ALARM	Fault name	Recommended inspection
02A77	CONTACTOR OPEN	Main contactor open	1. Broken circuit of main contactor coil. 2. Main contactor damaged
	end teach ko		Not used in BYD system
02A78	VACC NOT OK	Accelerator fault	Inspection time: With the forklift idling, the accelerator voltage is at least 1V higher than the minimum set in the "PROGRAM VACC" menu for accelerator signal range. Possible causes: 1.Upper and lower limits of accelerator voltage are not taken. Move to the PRPROGRAM VACC menu to take the limits again. 2.Accelerator error. Possible cause is that accelerator pedal failure to return to original position, or internal error of accelerator. 3.Controller fault.
	Possible causes:		
02A79	INCORRECT START	Startup sequence fault	Incorrect startup sequence. Possible causes: 1.The direction switch has already been turned on before the motor is turned on.2.Operation sequence error.3.Incorrect wiring connection. 4.If the fault cannot be eliminated, replace the controller.
	WRONG STEER PAR.		
	PUMP INC START	Oil pump startup sequence fault	Incorrect oil pump startup sequence. Possible causes: 1.The "LIFT" or "TLT" switch has already at the "ON" position before the forklift is started. 2.Operation sequence error. 3.Incorrect wiring connection. 4.If the fault cannot be eliminated, replace the controller.
02A80	FORW + BACK	Forward and reverse signals exist at the same time (direction switch gets stuck)	The controller can keep checking for this fault. Having detected that request signals in the two directions occur at the same time, the controller will issue a warning. Possible causes: 1.Wire damaged2.Direction switch fault3.Improper operation 4.If the fault cannot be eliminated, replace the controller
	EMERGENCY		
02A82	ENCODER ERROR	Encoder fault	The controller detects that two successive speed readings of the encoder differs greatly from each other. A normal encoder in the system cannot change speed readings greatly within a very short time. Hence, a possible cause for the symptom is that the wires of one or more encoders are worn or broken. Check the mechanical and electrical parts of the encoder. Another possible for the symptom is electromagnetic interference from the sensor bearing. If the symptom is not due to the two causes, replace the controller.Note: Sometimes manual operations may also cause this fault indicating on the controller. In these cases, it is required to turn off power supply and start the forklift again. For example:1.The forklift suddenly collides with an obstacle so that it is incapable of travelling;2.The driver applies the brake sharply while the forklift is travelling at a high speed.
02A84	CAN BUS KO BMS	BMS communication fault	Check whether the BMS communication line operates normally.
	canbus ko bms	BMS communication fault	Check CAN communication wire
02A85	VACC OUT RANGE	Accelerator input is outside the permissible range.	1. Upper and lower limits of accelerator voltage are not correctly taken. Move to the PRPROGRAM VACC menu to take the limits again; 2. Check whether the accelerator connection is correct;
02A86	PEDAL WIRE KO	Fault with connection of positive and negative terminals of accelerator	Check whether the positive and negative terminals of the accelerator have been connected to the controller;
	POS.EB.SHORTED	High end of drive of electromagnetic brake provides output earlier than expected	High end of drive of electromagnetic brake outputs high voltage with the interlock not engaged. 1. Check whether another high voltage circuit is connected to the high end output connector of electromagnetic brake; 2. If the high end output connector of electromagnetic brake is not connected but high voltage still exists, the drive circuit in the controller has already been damaged;

Display	ALARM	Fault name	Recommended inspection
02A89	POWER MOS SHORT	Short circuit of the power MOS tube	Before the main contactor engages, the software can check the power bridge. Convert the low end power of the MOS tube. Lower the phase voltage to -BATT (lift to +BATT). If the phase voltage variation does not agree with the command, this fault can occur. Replace the controller. Replace the controller.
	PUMP VACC NOT OK	Oil pump lift speed regulation sensor fault	Inspection time: With the forklift idling, the lift speed regulation sensor voltage is at least 1V higher than the minimum set in the "PROGRAM VACC" menu for accelerator signal range. Possible causes: 1.Upper and lower voltage limits of the lift speed regulation sensor have not been taken. Move to the "PROGRAM VACC" menu and take them again;2.Lift speed regulation sensor error;3.Controller fault.
	pev not ok		Not used in BYD system
02A90	PUMP VACC RANGE	Oil pump lift speed regulation sensor signal is outside the range	1. Upper and lower voltage limits of the lift speed regulation sensor have not been correctly taken. Move to the "PROGRAM VACC" menu and take them again; 2. Check whether the wiring of the lift speed regulation sensor is correct;
	lift+lower	Trigger the lifting and lowering at the same time	Check if the tiller switch signal is normal
02A91	lift low active	Lowering switch is triggered	The lowering switch is triggered when the vehicle is turned on, please check the lowering switch
02A92	CURRENT GAIN	Fault with current gain	Maximum current gain is the factory set value. It indicates that the maximum current adjustment procedure has not yet been initiated. Solution: ZAPI technician correctly sets the current gain parameter.
	canbus ko tiller	Tiller communication fault	Check CAN communication wire
02A93	wrong battery	Voltage level setting error	Check whether the battery voltage is normal.
02A94	data acquisition	Data update error	Controller parameter settings cannot be changed while the controller is working.
02A95	INPUT ERROR #2	Input error #2	
02A96	ANALOG INPUT	Analogue signal input fault	This fault occurs when all analogue signals are converted into the same value by the A/D converter, with delay exceeding 400ms. This function is used to detect fault with the A/D converter or conversion of analogue signal. Fault analysis: If this fault persists, replace the controller.
02A97	input error#1		Check whether A13 input is normal
02A98	reload hm from mdi		Not used in BYD system
	input error#2		Check whether A14 input is normal
02A99	SLIP_PROFILE	Slip fault	"SLIP_PROFILE" selection error. Check hardware parameter settings.
	checkup needed	Checkup needed	Check interval is expired. Contact the service personnel to check.
06A00	STEER HAZARD	Steering angle exceeds limit	1. Reduce the steering angle and restart the key; 2. Change the internal angle parameter setting of steering controller;
	EMERGENCY	Emergency reverse	After completing the emergency reverse, engage the interlock switch again and the fault disappears.
	WAITING DATA	Waiting for data	1.Check if the CAN BUS communication line is connected properly; 2.Check if the bit rate of the communication is consistent;
	EPS NOT ALIGNED	Zero not found	1.Check if the zero proximity switch is installed properly; 2.Check if the zero proximity switch is correctly selected; 3.Check if the output data of zero proximity switch is correct;
	WAITING FOR TRAC	Waiting for towing controller	1.Check if the CAN BUS communication line is connected properly; 2.Check if the connection line of interlock switch is correct; 3.If the interlock switch is controlled by tiller, set TILLER SEITCH as HANDLE;
	KEYOFF	Key switch voltage low	1.Check if the key switch voltage receives a low voltage pulse when turning on the external load; 2.Check if B+ and B- are firmly connected to the controller; 3.If the fault is reported every time the key is turned on, replace the controller;
06A01	HIGH CURRENT	Current over high	1. Check if the steering controller matches the motor; 2. Replace the controller
06A02	POWER FAILURE #1	Power fault #1	1. Check if the controller fuse is normal; 2. Check if power supply cable is firmly connected to the controller; 3. Check if the controller W phase wire is connected properly; 4. Replace the controller;
06A03	POWER FAILURE #2	Power fault #2	1. Check if the controller fuse is normal; 2. Check if power supply cable is firmly connected to the controller; 3. Check if the controller U phase wire is connected properly; 4. Replace the controller;
06A04	POWER FAILURE #3	Power fault #3	1. Check if the controller fuse is normal; 2. Check if power supply cable is firmly connected to the controller; 3. Check if the controller V phase wire is connected properly; 4. Replace the controller;
06A05	STBY I HIGH	Standby current is high	Checks whether the motor current is zero via controller in the vehicle standby state. If it is not zero, this fault occurs, stop the vehicle immediately. Possible cause: 1. One end of the terminal is connected directly to another load rather than to a drive motor, such as a lift motor. 2. Current sensor or logic card damaged. Replace the logic card first. If the fault persists, replace the power part.

Display	ALARM	Fault name	Recommended inspection			
06A06	D LINE SENSOR KO	Step motor D LINE voltage failure	1.Check if the stepper motor cable is intact; 2.Resistance between D line and B- too small (Approaching 30Ω);			
06A07	Q LINE SENSOR KO	Step motor Q LINE voltage failure	1.Check if the stepper motor cable is intact; 2.Resistance between Q line and B- too small (Approaching 30Ω);			
06A08	EEPROM KO	Memory is damaged	Forklift does not travel. Parameter storage becomes faulty so that forklift stops operation. Operate the key switch for several times. If the fault still exists, replace the logic card. If the fault disappears, parameters previously stored have been replaced by wrong parameters. It is imperative to set the parameters again.			
06A09	VMN NOT OK	VMN fault	Replace the controller;			
06A10	HIGH TEMPERATURE	Temperature overheating	When full power is allowed, the temperature of the controller exceeds 85 °C (this temperature is related to the parameter "MAXIMUM CURRENT"). Corresponding relation is as follows: Parameter setting Alarm temperature MAXIMUM CURRENT=50% 96° C MAXIMUM CURRENT=60% 94° C MAXIMUM CURRENT=70% 92° C MAXIMUM CURRENT=80% 90° C MAXIMUM CURRENT=90% 88° C MAXIMUM CURRENT=100% 86° C At this time, the maximum current of the controller decreases with increasing temperature. When the temperature is 105 °C, the controller current is reduced to 0. If the chopper is in a cold state, the fault occurs: 1. The temperature calibration parameter of logic card is incorrect. Check the parameter. 2. The internal temperature sensor of the controller has fault. 3. Check if the temperature sensor itself is damaged.			
			06A11	DATA ACQUISITION	Data collection	Activation of this fault indicates data acquisition is under way. Wait data acquisition is completed.
06A12	LOGIC FAILURE #1	Logic card fault 1	Faults caused by under-voltage or over-voltage protection. In 24V system, the controller detects a voltage above 45V or below 9V; In 48V system, the controller detects a voltage above 65V or below 11V Possible causes: 1.Whether there is short circuit in the circuit system, such as DC-DC, brake coil, etc., or whether the controller input power supply is in good contact. (Driving controller) 2.Whether the battery voltage is over low or over high. (Driving controller) 3.Check if the power cable above the terminals such as B+, B-, main contactor is tight. (Driving controller) 4.Whether the calibration parameter of controller voltage is consistent with the actual voltage. (Driving controller) 5.Fault with the hardware circuit protected by over-voltage on the logic card. Replace the controller. (Driving controller) 6.The voltage between W and U does not meet the requirements, and the controller needs to be replaced; (Steering controller)			
			06A13	LOGIC FAILURE #2	Logic card fault 2	The voltage between W and V does not meet the requirements, and the controller needs to be replaced; (Steering controller)
			06A14	LOGIC FAILURE #3	Logic card fault 3	The output VU-VV of the voltage amplifier exceeds 2.2V-2.8V, and the controller needs to be replaced; (Steering controller)
			06A15	LOGIC FAILURE #4	Logic card fault #4	The output VW-VV of the voltage amplifier exceeds 2.2V-2.8V, and the controller needs to be replaced; (Steering controller)
			06A16	KS CLOSED	Safety contactor of slave contactor closed in advance	Main contactor monitors the advanced close of safety contactor of slave contactor, and the controller needs to be replaced;
06A17	KM CLOSED	Safety contactor of main contactor closed in advance	Slave contactor monitors the advanced close of safety contactor of main contactor, and the controller needs to be replaced;			
06A18	KS OPEN	Safety contactor of slave contactor open	Main contactor monitors the open of safety contactor of slave contactor, and the controller needs to be replaced;			

Display	ALARM	Fault name	Recommended inspection
06A19	KM OPEN	Main contactor of slave contactor open	Slave contactor monitors the open of safety contactor of main contactor, and the controller needs to be replaced;
06A20	MAIN CONT.OPEN	Main contactor open	The coil of main contactor has been energized by the logic card, but the contactor does not engage. Possible cause: 1.The contactor has mechanically become faulty, or its contacts get stuck 2.The contacts of contactor cannot make securely 3.If the contactor operates normally, replace the controller.
06A21	MICRO SLAVE	The information on the status bus between the main microprocessor and slave microprocessor is frozen to the OXFF value.	The controller should be replaced;
06A22	S.P OUT OF RANGE	Output steering potentiometer out of range	If a single potentiometer, such as CPOC1 end, is out of range 0.8V-4.2V, it will alarm. When the dual potentiometer is selected, the sum of the two sliding ends (CPOC1+CPOC2) is out of the range of 4.4V-5.5V and it will alarm. Check the connection of potentiometer.
06A23	F.B OUT OF RANGE	Feedback of steering motor encoder out of range	Feedback potentiometer (CPOT connecting to CNB#6) has fault, it will alarm. The range of CPOT is out of 0.3V-4.7V, it will alarm. Check if the steering motor encoder is connected correctly and whether there is an open circuit;
06A24	MICRO SLAVE KO	Main and slave microprocessor detection does not match	1.When using a stepper motor, the direction of the stepper motor detected by the main microprocessor and slave microprocessor is inconsistent; 2.In the closed-loop control system, the direction of the stepper motor detected by the main contactor is incorrect and is inconsistent with the direction of the stepper motor detected by the slave contactor; 3.The main contactor did not detect the steering limit position, but it was detected by the slave contactor;
06A25	ENCODER ERROR	Encoder fault	The controller detects that two successive speed readings of the encoder differs greatly from each other. A normal encoder in the system cannot change speed readings greatly within a very short time. Hence, a possible cause for the symptom is that the wires of one or more encoders are worn or broken. Check the mechanical and electrical parts of the encoder. Another possible for the symptom is electromagnetic interference from the sensor bearing. If the symptom is not due to the two causes, replace the controller. Note: Sometimes manual operations may also cause this fault indicating on the controller. In these cases, it is required to turn off power supply and start the forklift again. For example: 1.The forklift suddenly collides with an obstacle so that it is incapable of travelling; 2.The driver applies the brake sharply while the forklift is travelling at a high speed
06A26	BAD ENCODER SIGN	Encoder phase sequence error	Change encoder A, B phase;
06A27	GAIN EEPROM KO	EEPROM memory current value is different	Replace the controller;
06A28	CAN BUS KO	CAN BUS communication fault	1.Check if the CAN BUS communication line is connected properly; 2.Check if the bit rate of the communication is consistent; 3.Check if the CAN communication is open; 4.Check if the CAN communication loop resistance is 60Ω.
06A38	POSITION ERROR	Position error	1.Check if the steering motor encoder A and B phases are loosely connected; 2.Check if the steering motor A and B phases receive interference;
06A39	SERIAL ERROR #1	Slave contactor does not receive the information of main contactor from serial port	Replace the controller;
06A40	MICRO SLAVE #4	Steering motor current is opposite to the command direction	Replace the controller;
06A41	SLAVE COM. ERROR	Main contactor does not receive the information of slave contactor from serial port	Replace the controller;
06A43	CURRENT GAIN	Controller maximum current is not controlled	Replace the controller;
06A44	CLOCK PAL NOT OK	Clock error	Replace the controller;
06A45	STEER SENSOR KO	Dual potentiometer fault	Check the wiring and output of the two-way steering potentiometer.
06A46	JERKING FB	Steering potentiometer voltage changes too much	Replace the feedback potentiometer;
06A47	FB POT LOCKED	Feedback value of steering potentiometer locked	1.Check if the feedback steering potentiometer has mechanical looseness; 2.Check if there is a mechanical limit; 3.Check if the feedback steering potentiometer reaches its own limit point; 4.If the fault occurs in the opposite direction of the steering wheel during installation, adjust the direction of the steering wheel;
06A48	MOTOR TEMPERAT.	Motor temperature high	1.If the motor temperature digital switch is turned on, or analogue signal exceeds the cutout value, then the fault results.2.When motor temperature rises to 120° C, the controller will display the warning. The forklift still can travel but the maximum current is reduced with the forklift performance degraded. When the motor temperature reaches 125° C, the motor stops working. In this case, action shall be taken to cool the motor.3.The fault still exists when the motor cools, check the line. If all have no faults, replace the controller.

Display	ALARM	Fault name	Recommended inspection
06A49	MOTOR LOCKED	Steering motor stalling	Steering motor continuous maximum current time exceeds 1s;
06A50	STEPPER MOT MISM	Frequency of stepper motor Q and D line and voltage values do not match	Replace the controller;
06A52	MICRO SLAVE #8	The encoder of the main microprocessor is inconsistent with the encoder of the slave microprocessor	Replace the controller;
06A53	INPUT ERROR #1	Advanced steering controller CAN#4 has a voltage input higher than 12V	Check if the CAN#4 cable is correct;
06A54	CAN BUS KO SL	Slave contactor does not receive any CAN information from main contactor	Replace the controller;
06A55	SL EPS NOT ALL	Self centering is not completed	Replace the controller;
06A56	SL CENTERING	Swing angle of self centering is out of range	Replace the controller;
16A06		Communication fault	Check the CAN cables of control handle, instrument panel, and steering controller
17A01	battery high temp. waring	Battery high temperature warning	
17A02	battery high temp. alarm	Battery high temperature alarm	
17A03	battery leakage waring	Battery leakage warning	
17A04	battery leakage serious	Battery leakage alarm	
17A05	battery Status Alarm	Battery status alarm	
17A06	BDI low	Battery level low (SOC ≤ 10%)	
17A07	BDI low	Cell voltage too low, general warn-ing	
17A08	BDI low	Cell voltage too low, severe warning	

## OTHER INFORMATION

## Contact Information

Importer: BYD Europe B.V.  
Address: s-Gravelandseweg 256, 3125 BK Schiedam, Netherlands  
Tel: +31-10-2070888 Fax: +31-10-2070880

Importer: BYD Motors Inc.  
Address: 1800 South Figueroa Street, Los Angeles, CA, 90015  
Tel: 213-748-3980 Fax: 213-748-3945  
E-mail: FORKLIFTSERVICE@BYD.COM

Importer: BYD do Brasil  
Address: Av. Antonio Boscato, 230 Terminal Intermodal de Cargas – TIC, CEP 13069-119 CAMPINAS - SP  
Tel: +55193514-2551  
E-mail: FORKLIFTSERVICE@BYD.COM

Importer: BYD Japan company Limited  
Address: The fifth Yasuda Bldg.5F,2-20-3 Tsuya-cho, Kanagawa-ku, Yokohama-shi,Kanagawa-ken,221-0835,Janpan  
Tel: 045-290-6550; 045-290-6616 Fax: 81-(0)45-319-1506

Importer: BYD Auto Industry Company Limited  
Address: No.3009, BYD Road, Pingshan, Shenzhen, 518118, P.R.China  
Tel: +86-755-89888888 Fax: +86-755-84202222

Manufacturer: BYD (SHAOGUAN) CO., LTD.  
Address: No.1, BYD Road, Zhenjiang Industrial Zone, Shaoguan, Guangdong, 512040, P.R.China  
Tel: +86-751-810 8888



*Build Your Dreams*