

# EPS14Pi

## USER MANUAL

< OM-EPS14Pi2019001-EN >



BYD FORKLIFT

# EPS14Pi

## USER MANUAL

< OM-EPS14Pi2019001-EN >



BYD FORKLIFT

## CONTENTS

## INTRODUCTION

## DESCRIPTION

STATEMENTS	9
HAND OVER FORKLIFTS	9

## SAFETY OPERATION SPECIFICATION

## NOTES FOR USERS

DRIVING LICENSE	11
WARNING SIGNS	12

## INTRODUCTION OF THE ENTIRE FORKLIFT

## SHAPE, TECHNICAL PARAMETERS AND OPERATING ENVIRONMENT

SHAPE OF THE ENTIRE FORKLIFT	14
TECHNICAL PARAMETERS	15
DIMENSION FIGURE OF THE ENTIRE FORKLIFT	15
PARAMETER TABLE OF THE ENTIRE FORKLIFT	16
OPERATING AND STORAGE ENVIRONMENT	17

## NAMEPLATES AND SIGNS

NAMEPLATE OF THE THIRE FORKLIFT	18
NAMEPLATE OF THE BATTERY	19
LOAD DIAGRAM	20
OTHER SIGNS	20

## OPERATION

## START AND CONTROL

IGNITION SWITCH	22
-----------------	----

EMERGENCY STOP SWITCH	22
PEDAL	22
CONTROL HANDLE	23
DRIVING, STEERING AND BARKING	24
LOW-SPEED SWITCH	25
LOWER AND LIFT THE PALLET FORK	26
LIFT AND LOWER DOWN THE REAR FORKLIFT BODY	26
PERFORM SYNCHRONOUS OPERATION OF STACKING AND	27
TRANSPORTING HORN	27
ANTI-COLLISION SWITCH	28

## OPERATING INSTRUMENT

INSTRUMENT (TYPE A)	29
INSTRUMENT (TYPE B)	30

## TRANSPORTING GOODS

LOADING	31
DRIVING	32
UNLOAD	32
LEAVE	32

## BATTERY

CHARGE	33
--------	----

## TRANSPORTATION AND STORAGE

## LOADING, TRANSPORTING AND UNLOADING FORKLIFTS

LIFT FORKLIFTS	35
SELF-LOADING	35
TRANSPORTING AND UNLOADING	36

## STORAGE AND RESTARTING

PROCEDURES OF STORAGE	37
PROCEDURES OF RESTARTING	37

## MAINTENANCE OF VEHICLES

### DAILY MAINTENANCE

TIME AND ITEMS	39
DESCRIPTION	40

### REGULAR MAINTENANCE

TIME AND ITEMS	42
DESCRIPTION	43

### ACCESSOZRY

CATEGORY, DOSAGE AND MODEL OF ACCESSORY	44
---	----

### BEFORE MAINTENANCE

BEFORE MAINTENANCE	45
EMERGENCY DESCENT	45
TOWING FAULTY VEHICLES	46

### MAINTAIN CHASSIS

CHECK AND ADJUST BALANCE OF THE ENTIRE FORKLIFT	47
REPLACE SUPPORT WHEELS	48
REPLACE BALANCE WHEELS	49
REPLACE DRIVE WHEELS	50
CHECK LEVEL OF GEAR OIL AND ADD GEAR OIL	51
REPLACE GEAR OIL	52

### MAINTAIN MAST

ADJUST CHAIN	53
LUBRICATE CHAIN	55
CLEAN MAST	55
ADJUST MAST CLEARANCE	56

### MAINTAIN HYDRAULIC DEVICE

ADD HYDRAULIC OIL	58
REPLACE HYDRAULIC OIL	59

### MAINTAIN ELECTRIC DEVICE

CHECK CIRCUIT	60
CHECK THE MAIN CONTROLLER	60
CHECK LOW-VOLTAGE SAFETY DEVICE AND RELAY	60

### CHECK TORQUE OF KEY FASTENERS

CHECK TORQUE OF WHEEL FASTENERS	61
CHECK FASTENERS TORQUE OF THE MAST	62

### SCHEMATIC DIAGRAMS

HYDRAULIC SCHEMATIC DIAGRAM	63
ELECTRICAL SCHEMATIC DIAGRAM	64

### TABLE OF FAULT CODES

TABLE OF FAULT CODES	65
----------------------	----

## OTHER INFORMATION

CONTACT INFORMATION	74
---------------------	----

# INTRODUCTION

Thanks for your using BYD forklift.

The user manual is designed to show correct operation of BYD forklift and procedures related to checkup, protection and maintenance thereof. Please refer to relevant chapters for more details.

Please read the user manual carefully before carrying out operation so as to operate and maintain forklifts correctly. When a forklift is borrowed or transported, please make sure that this manual is taken with operators so that it can be used at any time.

When you check the user manual, please note tips containing the following signs:

## Danger

It indicates imminent danger. If not avoided, it may result in death or serious injury, or serious property loss.

## Warning

It indicates potential danger. If not avoided, it may result in death or serious injury, or serious property loss.

## Caution

It indicates potential danger. If not avoided, it may result in mild or moderate injury, or some property damage.

## Note

It indicates tips of operation details. Obeying these tips of details can better your operation.

# DESCRIPTION

## STATEMENTS

The industrial forklifts produced by our company are solely used for available factory sites and special areas allowed by Regulation on Special Equipment Safety Supervision.

All losses resulted from improper use shall be undertaken by users themselves, and our company does not undertake any responsibility. If you need to use purchased forklift in a special environment not mentioned in this manual, please negotiate with local dealers of BYD.

Without written permission of our company, any change on the forklift shall not be allowed. If necessary, please negotiate with our company.

If the purchased forklift is equipped with other appliances beside fork, please load goods in accordance with the loading nameplate thereof. All appliances are equipped with the user manual, please read carefully.

This manual is made based on a standard forklift. If you have any doubt about the purchased forklift, please be free to consult the after-sales personnel of BYD electric forklifts.

Our company will continuously develop products and constantly improve the design and structures of products. Our company reserves the right to modify and interpret shape, equipment, expertise and technical parameters. Our company shall not accept any appeal based on the technical indicators, pattern and specifications in this manual.

## HAND OVER FORKLIFTS

Each certificated forklift has been performed a complete test for its functions in the factory, and has been protected well during the transportation process. Despite all this, our company can't guarantee that the forklift is free of damage during the transportation process. Therefore, in order to ensure the normal operation of the forklift, you shall inspect and accept carefully and shall be obliged to re-inspect the following items when handing over the forklift:

1. Check tightness of the wheel nuts
2. Check the level of hydraulic oil
3. Check braking function
4. Check driving function
5. Check steering function
6. Check mast and operating function of accessories
7. Check whether high-voltage connection terminals of electric devices are loose.

In order to avoid the inconvenience from the claim afterwards, please check whether the functions and configuration of the forklift are complete.

## SAFETY OPERATION SPECIFICATION

This chapter will describe safe operation specification when you use BYD electric forklifts.

Operators should have a driving license and operate the forklift in accordance with the specification.

Before operating the forklift, please find the nameplate and load diagram of the forklift and confirm its attributes and carrying capacity, so as to avoid overload operation of the forklift.

Please find signs posted around the forklift and get familiar with these contents.

## NOTES FOR USERS

### DRIVING LICENSE

1. Only a qualified, trained and experienced person is authorized to operate the industrial forklift under the law. The user or other entrusting party must confirm the driving license of the operator first and authorize the operator to operate after the corresponding driving test.
2. The company responsible for operating shall ensure that the driver can identify the nameplate and load diagram of the forklift as well as safety warning signs attached on the forklift, learn and obey the notes in the manual.
3. A company or responsible person shall comply with all regulations and safety guidelines applicable to industrial forklifts. Please obey relevant regulations and safety guidelines, for example:
  - (1) Operating regulations for industrial vehicles
  - (2) Regulations on lane and operating areas
  - (3) Driver's rights and obligations and code of conduct
  - (4) Special operating areas
  - (5) Daily maintenance
  - (6) Regular maintenance

Danger

1. Only authorized person can use the forklift.
2. A safety device (such as OPS system) can provide security for you. All types of safety devices shall not be forbidden.
3. Goods should be kept with shape neat and center of gravity centered so as to avoid slipping.
4. Do not make any private changes. If necessary, please contact dealers or after-sale personnel of BYD.
5. Do not overload. Please confirm the rated load and the load center on the weight table before operating. Please obey marking weight on the load nameplate of appliance when installing other appliances.
6. Do not operate the forklift after drinking. Otherwise, it may cause heavy casualties.

Caution

- (1) Please read the manual before operation.
- (2) Operators should wear work shoes and clothes.
- (3) Do not drive with wet or greasy hands.
- (4) Carry out daily check and regular maintenance for forklifts.
- (5) Stop operation immediately if any damage or abnormality is found to the forklift.  
Don't operate until the forklift is completely restored.

## WARNING SIGNS

1. The warning signs attached on the forklift remind the driver of potential danger and notes. Please find and read these signs carefully.
2. If you find the warning sign of the forklift is not clear or is moved, please contact local dealer of BYD for replacement.

**INTRODUCTION OF THE ENTIRE FORKLIFT**

This chapter will show an overview and relevant technical parameters of the forklift.

SHAPE, TECHNICAL PARAMETERS AND OPERATING ENVIRONMENT

TECHNICAL PARAMETERS

SHAPE OF THE ENTIRE FORKLIFT

DIMENSION FIGURE OF THE ENTIRE FORKLIFT

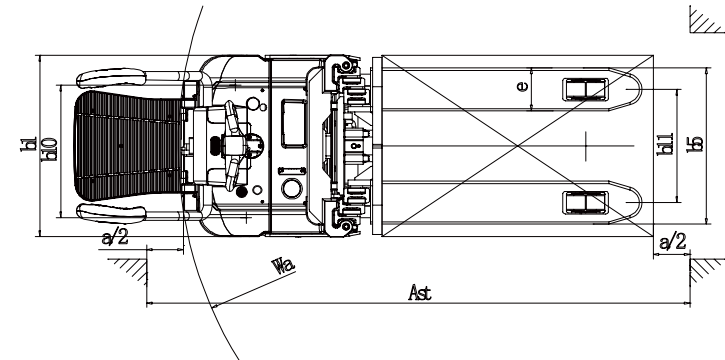
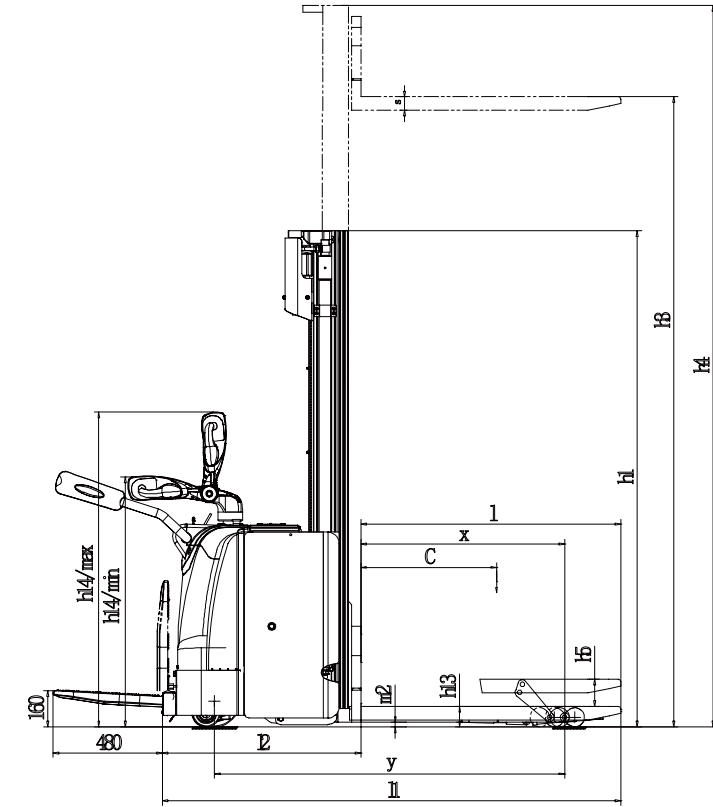
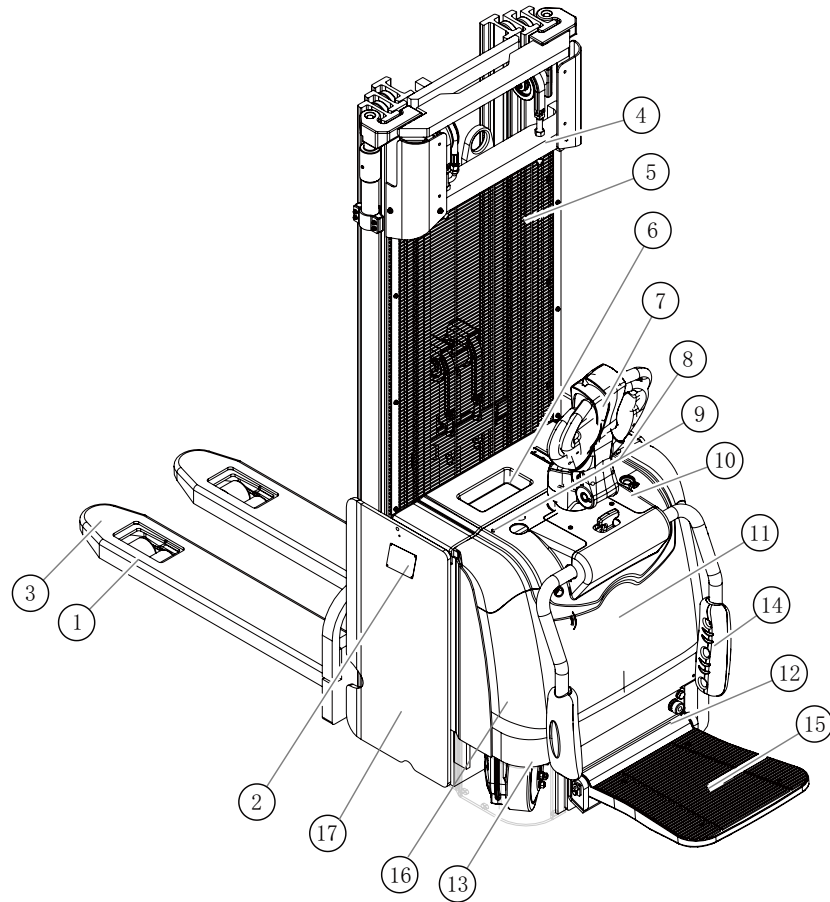

NO.	PART NAME	NO.	PART NAME	NO.	PART NAME
1	SUPPORT WHEEL	7	CONTROL HANDLE	13	DRIVE WHEEL
2	NAMEPLATE OF THE ENTIRE FORKLIFT	8	EMERGENCY STOP SWITCH	14	GUARDRAIL
3	FORK	9	INSTRUMENT	15	PEDAL
4	MAST	10	IGNITION SWITCH	16	FRONT FORKLIFT BODY
5	GRID GUARD	11	GUARD PLATE	17	REAR FORKLIFT BODY
6	UPPER COVER PLATE	12	BALANCE WHEEL		



PARAMETER TABLE OF THE ENTIRE FORKLIFT

FEATURES	MANUFACTURER		BYD
	MODEL		EPS14Pi
	OPERATING MODE (WALKING TYPE AND STAND UP)		Stand up
	LOAD CAPACITY	Q (kg)	1400
	LOAD CENTER DISTANCE	C(mm)	600
	FRONT OVERHANG	X(mm)	901
WEIGHT	WHEEL BASE	y(mm)	1600
	TOTAL WEIGHT (BATTERY INCLUDED)	kg	1420
	AXLE LOAD WHEN MAST IS TAKEN BACK WITH FULL LOAD, DRIVE SIDE / BEARING SIDE	kg	1290/1350
WHEEL	AXLE LOAD WHEN MAST IS TAKEN BACK WITH NO LOAD, DRIVE SIDE / BEARING SIDE	kg	900/340
	WHEEL, DRIVE SIDE / BEARING SIDE		POLYURETHANE
	DIMENSION OF THE TIRE DRIVE SIDE		Φ230X82
	DIMENSION OF THE TIRE BEARING SIDE		4XΦ85X70
	DIMENSION OF THE ACCESSORY WHEEL		2XΦ120X50
DIMENSION	NUMBER OF WHEELS (X= DRIVE WHEEL) DRIVE SIDE / BEARING SIDE		1X+1/4
	HEIGHT WHERE THE MAST IS RETRACTED	h1(mm)	2203
	FREE LIFT HEIGHT	h2(mm)	138
	LIFT HEIGHT	h3(mm)	3200
	MAST HEIGHT WHEN LIFT UP	h4(mm)	3717
	INITIAL LIFT HEIGHT	h5(mm)	120
	LIFT HEIGHT OF THE BOTTOM PART	h5(mm)	120
	MAX/MIN HEIGHT WHERE THE OPERATING HANDLE IS LOCATED IN THE DRIVING POSITION	h14(mm)	990/1288
	RETRACTING HEIGHT OF FORK	h13(mm)	90
	OVERALL LENGTH	l1(mm)	1729
	LENGTH OF THE FORK FRAME	l2(mm)	832
	OVERALL WIDTH	b1(mm)	800
	DIMENSION OF FORK	s/e/l(mm)	60/180/1150
	OUTER SPACING OF THE PALLET FORK	b5(mm)	560
	PERFORMANCE	OFF-GROUND CLEARANCE AT WHEELBASE CENTER	m2(mm)
DRIVE MOTOR	AISLE WIDTH (1000*1200)	Ast(mm)	2628
	AISLE WIDTH (800*1200)	Ast(mm)	2515
	TURNING RADIUS (LH/ RH)	Wa(mm)	1802
PERFORMANCE	DRIVING SPEED FULL LOAD/EMPTY	km/h	8/9
	LIFTING SPEED FULL LOAD/EMPTY	mm/s	160/230
	RATE OF DESCENT FULL LOAD/EMPTY	mm/s	370/230
	GRADEABILITY, FULL LOAD/EMPTY	%	9/16
DRIVE MOTOR	RIVE MOTOR POWER	kw	1.3
	LIFT MOTOR POWER	kw	3
	BATTERY VOLTAGE / CAPACITY	V/Ah	24/270

OPERATING AND STORAGE ENVIRONMENT

Temperature: -5 ~ 40° C

Humidity : ≤90%

Altitude: ≤2000m

Road surface: dry, hard, relatively flat, smoothly

Storage: be stored in a well - ventilated warehouse, but cannot be stored in the open air for a long time.

Caution

Decrease the weight of the goods or the run-ning speed when the working condition is poor.

Danger

- (1) No sharp obstacles on the road.
- (2) No strong acid base or strong polar solvents such as toluene and acetone on the road.
- (3) Do not immerse the wheels in water for a long time.
- (4) Do not expose to intense sunlight for a long time.
- (5) No flammable gas, flammable dust and volatile flammable liquid in the operating environment.

Notes

Please consult local forklift dealers of BYD before operating in the following environment:

- (1) With explosive substances such as ammunition
- (2) Dusty
- (3) A harbor or waterfront at risk of salt erosion
- (4) A chemical factory that may be affected by acid or other chemicals
- (5) Containing combustible dust and gas
- (6) With certain toxic substances
- (7) With radioactive substances
- (8) Other special environments

## TARGHETTE NOMINALI E SEGNALI

TARGHETTA NOMINALE DELL'INTERO CARRELLO ELEVATORE

CARRELLI PER IMPILAGGIO DI PALLET

MODEL		WEIGHT WITH NO LOAD	
NUMBER MANUFACTURING		WEIGHT(BATTERY EXCLUDED)	
RATED LIFT WEIGHT		RATED VOLTAGE	
MAX. LIFT WEIGHT		RATED CAPACITY	
WEIGHT OF BATTERY (MAX.)		PESO DELLA BATTERIA (MIN.)	

BYD

BYD(SHAOGUAN)CO.,LTD.

Production Address: No.1, BYD Road, Zhenjiang Industrial Zone, Shaoguan, Guangdong

Notes

- (1) The nameplate is on the left of the forklift.
- (2) Please check whether the information of the nameplate is consistent with the fork you order after you finish.

Caution

- (1) Please check the nameplate and identify its property because the configuration of each forklift is different.
- (2) When handling the material, the weight of the material should not exceed the rated lifting weight. Please check and confirm.

## NAMEPLATE OF THE BATTERY

BYD Iron-Phosphate Battery

Operating Conditions	Ambient Temperature	
	Relative Humidity	
Basic Performance	Model	
	Cell Model	
	Nominal Capacity	
	Nominal Voltage	
	Operating Voltage	
	Rated Operating Current	
	Weight	
	Serial No.	

Caution: Before operation, you must be familiar with specific requirement for output configuration by referring to the instruction manual.

Made in China

BYD (SHAOGUAN) CO., LTD.

Notes

- (1) The nameplate of the battery is posted on the battery box.
- (2) Please check whether information of the nameplate is consistent with the ordered forklift after you confirm receipt.

LOAD DIAGRAM

When the forklift increases its lift height , its load capacity decreases instead. According to the load diagram, the lift height corresponds to the rated lift capacity. It is supposed that the lift height of a material is 4300 mm and then we can get the follows:

- (1) A horizontal line drawn at the lift height of 4300mm will intersect the load diagram at one point.
- (2) A vertical line is made at the point and intersects with the x-axis at the another point. It is known that the rated lift weight at this height is 750 kg.

If you want to raise the lift height of the material, you should decrease its weight.

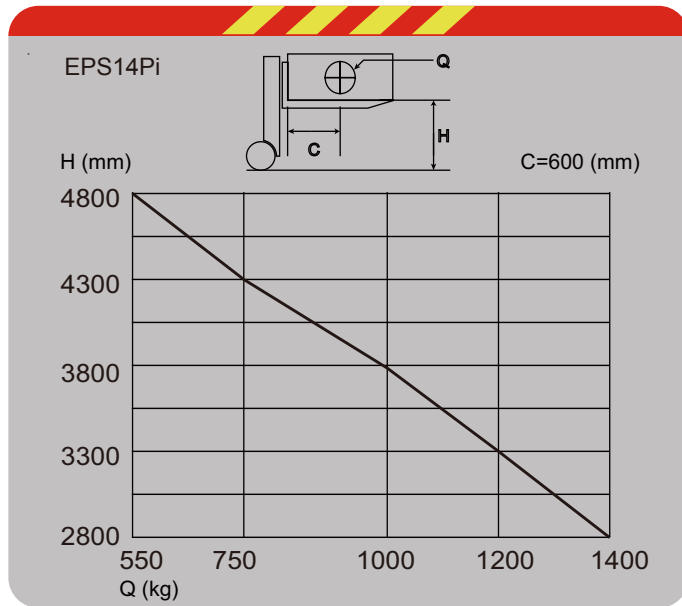

Notes

- (1) The configuration of the forklift varies with the customer's order. Please check the load diagram before using the forklift and confirm its carrying capacity.
- (2) The parameters on the load diagram correspond to compact and uniform cargo. The parameters cannot exceed the load limit. Otherwise, it will affect the stability of the forklift and the intensity of the associated parts.

OTHER SIGNS

Please pay attention to checking notes or warning signs posted around the track.

OPERATION

This chapter will describe how to operate BYD electric forklifts.

# START AND CONTROL

## IGNITION SWITCH

Insert the key into the ignition switch and rotate it clockwise to the “start” gear. When the forklift starts, the key will automatically return to the “on” gear.

When the forklift is powered on for a period of time, the forklift automatically powers off; at this time, rotate the key to “start” gear again and continue to operate.

Rotate it counterclockwise to the “off” gear and pull it out, then stop operating the forklift.

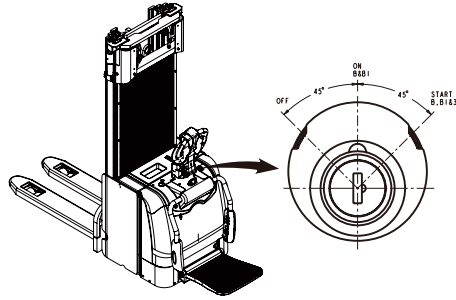

**Note**

Turn on the emergency stop button and then start the forklift.

## EMERGENCY STOP BUTTON

The forklift powers off when pressing the emergency stop button. The power supply will restart when turning up the emergency stop button.

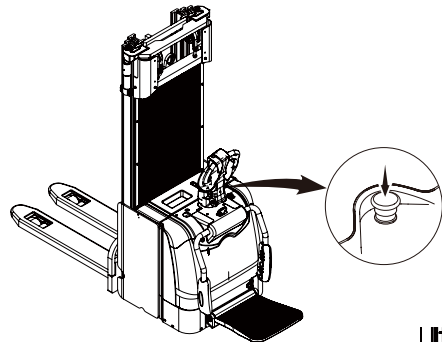

Guardrail and pedal

Guardrail

Before operating the forklift, open the guardrail to protect the operator when turning.

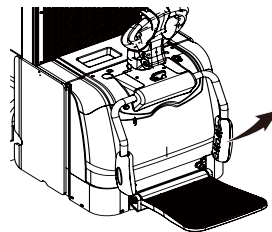

## PEDAL

Open the pedal downwards and then use it.

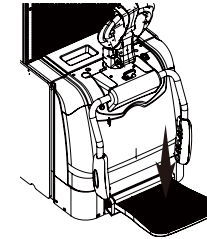

**Note**

If the guardrails and pedals are not opened, the running speed of a forklift will be limited. When the pedal safety switch and guardrail safety switch are triggered synchronously, the running speed will exceed 6km/h. When any of both switches is disconnected, the running speed will be less than 6km/h.

## CONTROL HANDLE

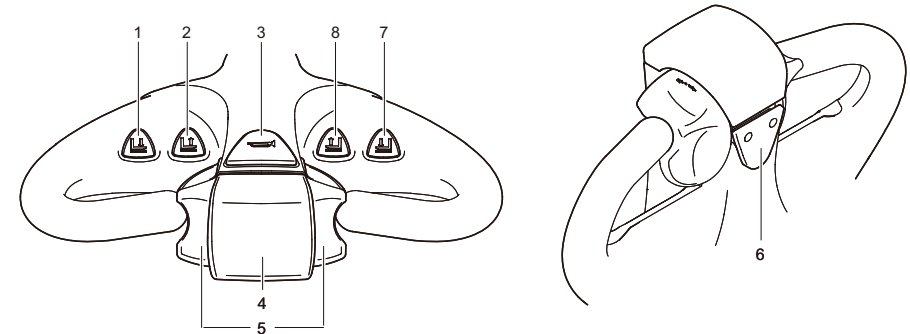

NO.	PART NAME	NO.	PART NAME	NO.	PART NAME
1	BUTTON FOR LOWERING REAR FORKLIFT BODY	4	ANTI-COLLISION SWITCH	7	BUTTON FOR LOWERING FORK
2	BUTTON FOR LIFTING REAR FORKLIFT BODY	5	DRIVING SWITCH	8	BUTTON FOR LIFTING FORK
3	HORN BUTTON	6	LOW-SPEED SWITCH		

DRIVING, STEERING AND BARKING

1. DRIVING

Place the control handle in area A2.

Turn the driving button forward or backward to realize driving forward or backward.

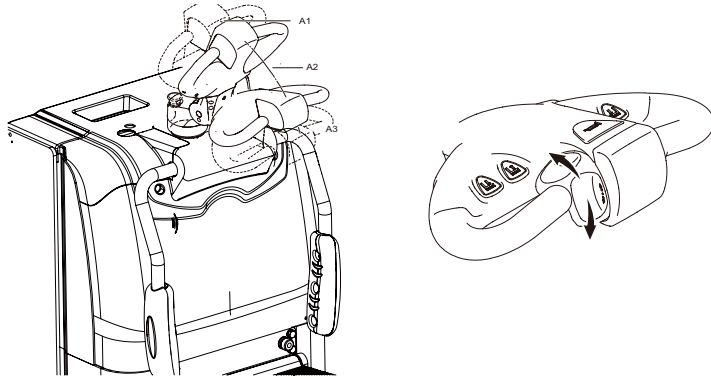

2. STEERING

Swing the control handle to the right or left so as to control steering when driving.

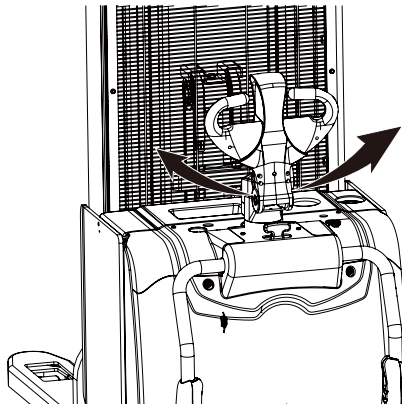

3. BARKING

The brake will be applied when the control handle is placed in areas A1 and A3. Release the acceleration button B and then the brake will be applied. When the speed of the forklift is 0, the forklift will brake immediately.

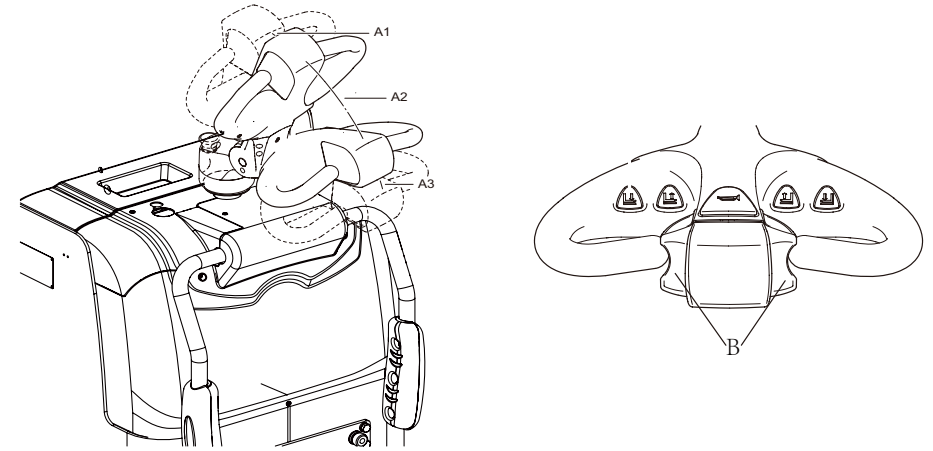

LOW-SPEED SWITCH

Press the button below the control handle to start the low-speed mode.



LOWER AND LIFT THE PALLET FORK

Press the button for lifting fork, and then the fork will rise. Instead, the fork will be lowered down. When the fork rises to the top and triggers the switch, it will not continue lifting. When the lift height of the mast exceeds h1 (300mm, adjustable), the speed limit switch will be triggered, the fork cannot be lifted during driving and the running speed will be less than V (set as 3km/h, adjustable).

When the height of the mast is between 0 and h1, the fork can be lifted during driving.

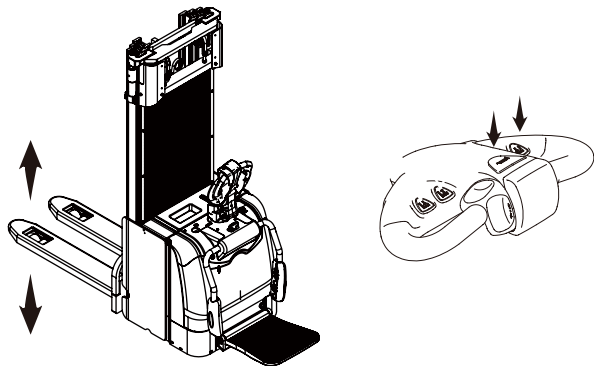

LIFT AND LOWER DOWN THE REAR FORKLIFT BODY

Press the button for lifting rear forklift body, and then the fork will be lifted.

Press the button for lowering down rear forklift body, and then the fork will be lowered down.

If any two operations (mast is lowered down and lifted or the rear forklift body is lowered down and lifted) are operated at the same time, report the fault and forbidding using the oil pump function.

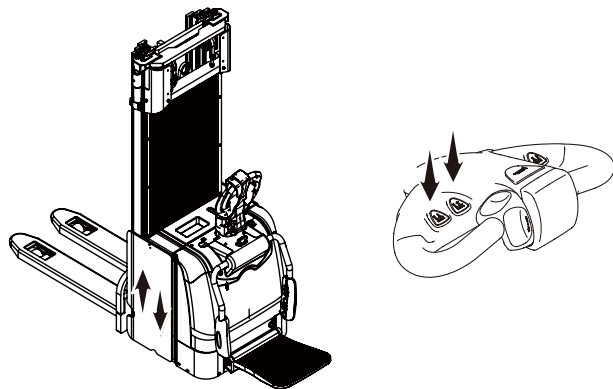

PERFORM SYNCHRONOUS OPERATION OF STACKING AND TRANSPORTING

According to the synchronous operation schematic diagram of stacking and transportation, the rated load Q (Unit: Kg) of the forklift is defined.

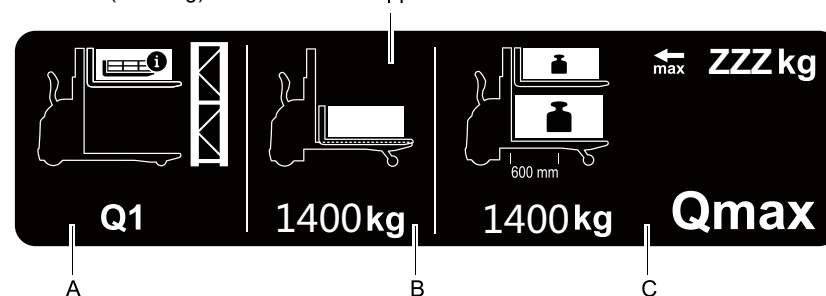

A=	Stacking (Unload or fork cargo): When lifting (forward leg), pay attention to the rated load depending on the lifting height.
B=	Transportation: When the forward leg is lifted (the mast is lifted), the maximum rated load value for level service is 1400Kg.
C=	Synchronous operation: Total maximum rated load under high lift operation (the mast is lifted) is ZZZKg. The maximum rated load when lifting (mast is lifted) and lowering (the forward leg is lifted) is 1400Kg in all.

When performing stacking operation, low lift (forward leg is lifted) can be performed to lift the cargo at a lifting height of 2800mm for storage. To achieve a lifting height of 2800mm, low lift (forward leg is lifted) must be lowered down.

Don't transport cargo when another cargo (>500mm) carried is lifted. Synchronous operation is excluded.

Under the synchronous operation, the maximum lift height is 2800mm.

HORN

Press the button to make the horn honk.

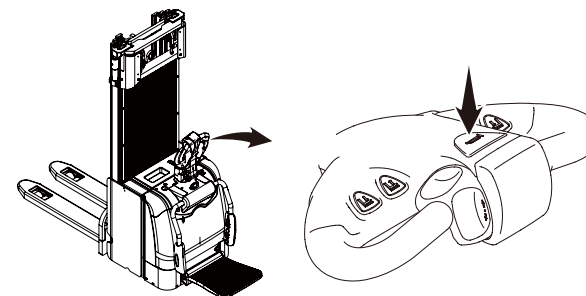

ANTI-COLLISION SWITCH

The forklift will move a short distance automatically once the anti-collision switch is bumped. It will not stop until the anti-collision switch is not bumped.

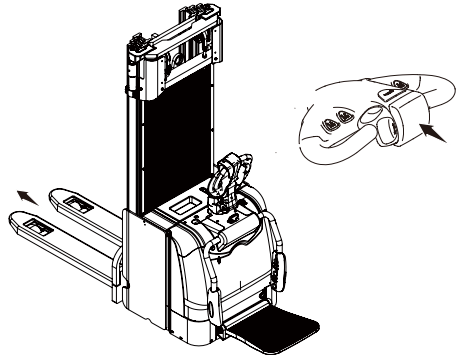

OPERATING INSTRUMENT

INSTRUMENT (TYPE A)

There are a display screen and an indicator on the instrument. The display screen shows information such as power, service tips, low speed tips, service time and fault code. The indicator is used to show inefficient power and maintenance.

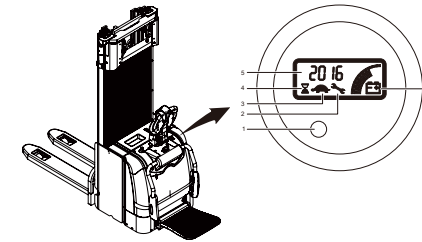

NO.	NAME	DESCRIPTION
1	ALARM INDICATOR LAMP	THE ALARM LAMP WILL LIGHT WHEN THE BATTERY POWER IS LOW OR THE FORKLIFT IS FAULTY.
2	MAINTENANCE ICON	THE ICON WILL APPEAR WHEN THE FORKLIFT IS FAULTY.
3	LOW-SPEED ICON	THE ICON WILL APPEAR WHEN THE LOW-SPEED BUTTON IS PRESSED.
4	TIMER ICON	THE ICON WILL APPEAR WHEN THE FORKLIFT STARTS NORMALLY.
5	INFORMATION ON TIME AND FAULT CODE	WHEN THE FORKLIFT STARTS NORMALLY, THE TIME WORKED WILL BE INDICATED. IF A FAULT APPEARS AFTER THE FORKLIFT STARTS, THE FAULT CODE WILL BE INDICATED.
6	BATTERY STATE	THE BATTERY LEVEL IS DISPLAYED AS 10 BARS, AND EACH BAR REPRESENTS 10% OF THE BATTERY LEVEL. THE NUMBER OF BARS DISPLAYED BY THE BATTERY LEVEL VARIES WITH THE ACTUAL BATTERY LEVEL OF THE FORKLIFT.

## INSTRUMENT (TYPE B)

There are a display screen and an instrument aperture on the instrument (Type B). The display screen shows information such as power, service time and fault code. When a controller is faulty, the instrument aperture will be shown as red, and the interface displays the current fault code.

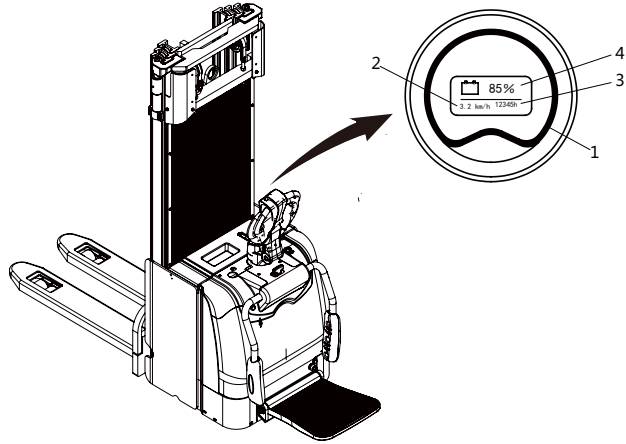

NO.	NAME	DESCRIPTION
1	ALARM INDICATOR	WHEN THE BATTERY POWER IS LOW OR THE FORKLIFT IS FAULTY, THE INSTRUMENT APERTURE WILL BE SHOWN AS RED, AND THE INTERFACE DISPLAYS THE CURRENT FAULT CODE.
2	SPEED INDICATOR	IT WILL DISPLAY CURRENT RUNNING SPEED WHEN THE FORKLIFT STARTS NORMALLY.
3	WORKING TIME INDICATOR	IT WILL DISPLAY TIME WORKED WHEN THE FORKLIFT STARTS NORMALLY.
4	BATTERY STATE	THE BATTERY POWER IS SHOWN AS PERCENTAGE.

## TRANSPORTING GOODS

## LOADING

## 1. GOODS ON THE GROUND

- (1) Drive the car carefully towards the position where goods are placed, and start the brake.
- (2) Put the fork on the ground.
- (3) Insert the fork exactly into the bottom of the goods.
- (4) Lift the fork.
- (5) Pay attention to the road condition and pedestrians when driving and keep an appropriate forklift speed. Send goods to an assigned place.

## 2. ELEVATED GOOD

- (1) Move the forklift towards the goods-storing position carefully and start braking.
- (2) Keep mast vertical and lift the fork to the bottom of goods.
- (3) Insert the fork into the bottom of goods perfectly.
- (4) Continue to lift the fork and take out goods completely.
- (5) Drive backwards carefully and slowly and takes goods completely out of the stacking area.
- (6) Lower the fork to a certain height.
- (7) Pay attention to the road conditions and pedestrians in the process of transportation, and maintain an appropriate speed. Then send goods to a assigned place.

Danger

- (1) Keep an appropriate speed when approaching to goods in order to avoid collision.
- (2) Do not stay below the lifting goods.

Caution

When loading goods, the shipper s72hall be responsible for fastening goods safely, ensuring that goods are compact, the center of gravity is in the center of goods.



## DRIVING

- (1) Do not make goods lean to one side when driving with loads.
- (2) Keep goods packed by the fork at an appropriate height.
- (3) Do not try to lift the fork when driving so as to avoid the fork imbalanced.
- (4) When the stack of goods is too high, the sight will be affected. Unless uphill, be sure to look back when driving backward.

Warning

- (1) The fork must be driven forward when the goods are carried uphill on the slope. When the goods are carried downhill, the fork should be driven backward. Keep a low speed when driving.
- (2) Do not cross the slope or turn around on the slope.

Caution

If the view is poor, please arrange a guide to guide the driving.

## UNLOAD

- (1) Drive the forklift carefully to the stock position and approach to it by braking and slowing down.
- (2) Lift the fork to an appropriate height.
- (3) Remove the fork from the bottom of the goods carefully and slowly.
- (4) Keep mast vertical and lower the fork to an appropriate position slowly so that goods can be separate from the fork completely.
- (5) Remove the fork from the bottom of the goods carefully and slowly.
- (6) leave and continue the next operation.

## LEAVE

- (1) Unload the goods and lower down the forklift.
- (2) Turn the key counterclockwise to OFF and remove it.
- (3) Press the emergency stop switch.
- (4) Leave.

## BATTERY

## CHARGE

Open the back plate of the battery cover. Then open the charging port, connect the charging connector and charge in accordance with the charger instruction.

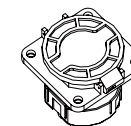
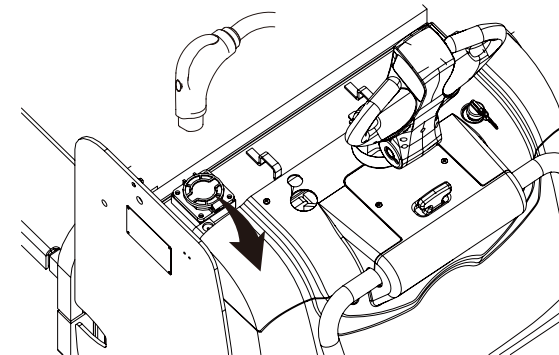

GB PORT

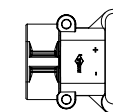

REM PORT (OPTIONAL)

Notes

- (1) When the forklift is in a prohibited state, stop charging before it can be used.
- (2) Since ambient temperature affects the charging time, it is recommended to charge at room temperature.

## TRANSPORTATION AND STORAGE

This chapter will describe how to transport and store forklifts.

## LOADING, TRANSPORTING AND UNLOADING FORKLIFTS

### LIFT FORKLIFTS

- (1) Lift the fork to the highest position.
- (2) Lift by hooking the lifting port of the upper mast.

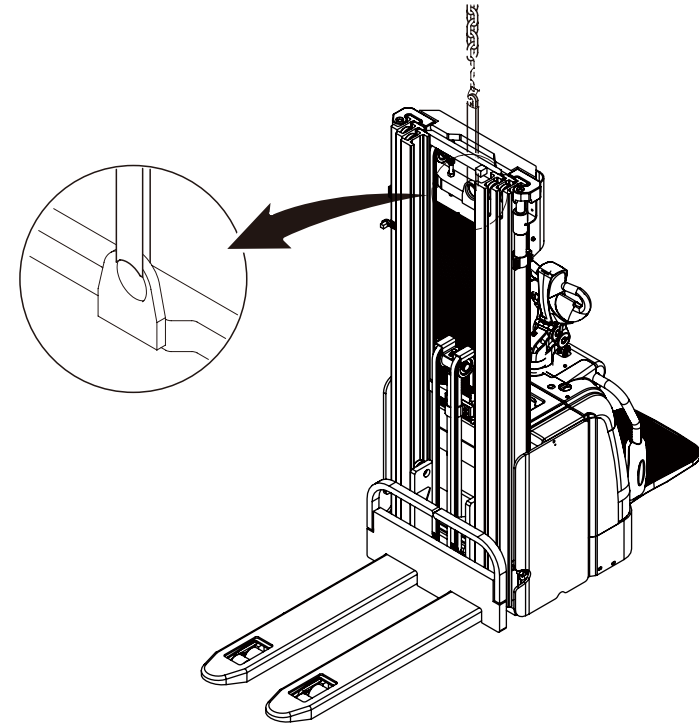

#### Danger

Ensure no one stays around the working area of the crane when lifting.

#### Warning

Use Lift equipment with sufficient load capacity when lifting forklifts.

### SELF-LOADING

Drive the forklifts onto the transport truck at a low speed.

Caution

- (1) Appoint an administrator to supervise.
- (2) Check whether the ground is hard enough so as to prevent the ground from sinking when loading forklifts.
- (3) Use a solid block to fix the transport truck.
- (4) Test the strength and stability of the ramp everywhere during loading and unloading.

## TRANSPORTING AND UNLOADING

- (1) Transport forklifts with trucks or flat trucks.
- (2) The procedures of unloading by lifting is consistent with those of loading.
- (3) Remove forklifts slowly from transport trucks. Other requirements are same as those of loading forklifts.

## STORAGE AND RESTARTING

## PROCEDURES OF STORAGE

Clear all dusts on the parts of forklifts and operate as follows.

- (1) Check whether there are oil leaks, water leaks, or abnormal parts. If any, please repair first.
- (2) Carry out complete lifting and lowering operation for several times.
- (3) Lower down the fork.
- (4) Apply a thin coat of grease to all unpainted parts.
- (5) Check the level of hydraulic oil. If necessary, add it.
- (6) Lubricate all components completely.
- (7) Pull out the key and ensure the electrical appliances in a rest state. Press the emergency stop switch, and make sure the battery power is controlled around 50%. Do not place with feed or full power for a long time.
- (8) Operate the vehicle monthly.

## PROCEDURES OF RESTARTING

Clear all dusts on the parts of forklifts and operate as follows.

- (1) Lubricate all components completely.
- (2) Lift and lower forks, forward and backward tilting masts for several times. If fitted with an accessory, operate it several times.
- (3) Check the charging of battery.
- (4) Check hydraulic and replace it if necessary.

Caution

For the first use after long-term storage, the forklift must be checked and tested before it can be used.

## MAINTENANCE OF VEHICLES

This chapter will describe how to maintain vehicles.

## DAILY MAINTENANCE

### TIME AND ITEMS

Daily items are inspected daily (or every 8 hours and weekly (or every 40 hours, whichever comes first. For example, if the working hours are less than 8 hours per day, the forklift shall be inspected daily. If the working hours are more than 8 hours per day, the forklift shall be inspected every 8 hours.

The list of items to be checked are as follows:

NO.	ITEMS	1 DAY	1 WEEK
		8HOURS	40 HOURS
1	SHAPE	CHECK	
2	WHEELS	CLEAN AND TIGHTEN	CLEAN AND TIGHTEN
3	MASK	CHECK	
4	HYDRAULIC DEVICE	CHECK	
5	INSTRUMENT	CHECK	
6	WARNING APPARATUS	CHECK	
7	BRAKE	CHECK	CHECK
8	DRIVING, STEERING AND OPERATING	CHECK	
9	ELECTRICAL CONNECTION TERMINAL AND FUSE		CHECK
10	CLEAN		CLEAN
11	OTHER ABNORMALITIES	CHECK	

#### Caution

Inspect before each operation.

#### Note

Review the last failure before routine inspection.

## DESCRIPTION

## 1. SHAPE

- (1) Check whether the forklift is damaged or deformed.
- (2) Check whether oil is leaked on the ground where forklifts are put.
- (3) Check whether nameplates or signs are complete.
- (4) Check whether parts are loose or fall off.

Note

If oil leaks, please identify the position and contact after-sale personnel of BYD.

## 2. WHEELS

- (1) Check whether the fastener of wheels is loose. If any, tighten it.
- (2) Remove debris embedded in the tire.
- (3) If wheels are worn seriously wherein the wear between left and right wheels are uneven, or rims are found broken or bent, please replace wheels.

## 3. MAST

- (1) Check whether the cylinder and oil tube on the working device leak.
- (2) Check whether the working device is distorted or broken and whether clamp devices such as bolts are loose or fall off.

## 4. HYDRAULIC OIL

Check the device through the level of hydraulic oil.

## 5. INSTRUMENT

- (1) Check whether the battery voltage and power on the instrument are displayed normally.
- (2) Check whether a fault indicating lamp appears on the instrument.

## 6. WARNING DEVICE

- (1) Press "horn" button and check whether the horn can honk.
- (2) Check whether other warning devices are working normally.

## 7. BRAKE PERFORMANCE

Put the handle lever in the brake area and check whether the brake performance is good.

## 8. DRIVING, STEERING AND CHECKING

- (1) Check whether the steering wheel can steer fluently and whether noise appears during the operation.
- (2) Check whether buttons can work normally.
- (3) Check whether fasteners are loose or fall.

## 9. Electric check

- (1) Check whether connection terminals of electric device are loose. If any, tighten it. Check whether joints among the wiring-connected sections are abnormally.
- (2) Check whether the safety device of the master controller works normally. If necessary, replace it. Check whether the copper bar of the master controller is burned. If necessary, replace it.
- (3) Check whether the low-voltage insurance and relay can work normally. If necessary, replace them.

Warning

Disconnect power before the electric check.

## 10. CLEARANCE

Clean forklifts.

## 11. OTHER ABNORMAL PARTS

Check whether there are other abnormal parts.

## REGULAR MAINTENANCE

### TIME AND ITEMS

The time for daily check and maintenance shall depend on whichever comes first. For example, if the service time within 6 weeks are less than 250 hours, the reference time will be calculated as 6 weeks. Otherwise, 250 hours are preferred. Other reference time is calculated likewise.

TYPE	ITEM	6 (WEEKS)	3	6	12	MONTHS
		250	500	1000	2000	HOURS
CHASSIS	CHECK GEAR OIL LEVEL	FIRST CHECK		CHECK		
MAST	ADJUST CHAINS	ADJUST				
	LUBRICATE CHAINS	LUBRICATE				
	CLEAN MAST	CLEAN				
	ADJUST CLEARANCE AMONG MASTS	ADJUST				
HYDRAU-MATIC	REPLACE HYDRAULIC OIL					REPLACE
	REPLACE OIL-FILLING FILTER WITH AIR FILTER					REPLACE
ELECTRIC	CHECK ELECTRIC PARTS	CHECK				
OTHER PARTS	CHECK TORQUE OF KEY FASTENERS					CHECK

#### Note

If the operating conditions are relatively poor, the maintenance period should be shortened and negotiated with the after-sale personnel.

### DESCRIPTION

#### 1. CHASSIS

Check level of gear oil. If necessary, add it.

#### 2. MAST

(1) Check tightness of the chain. If necessary, adjust it.

(2) Lubricate the chain.

(3) Clean the mast.

#### 3. HYDRAUMATIC

(1) Replace hydraulic oil regularly.

(2) Replace oil-filling filter with air filter regularly.

#### 4. ELECTRIC DEVICES

(1) Check whether connection terminals of electric device are loose. If any, tighten it.

Check whether joints among the wiring-connected sections are abnormally.

(2) Check whether the safety device of the master controller works normally. If necessary, replace it. Check whether the copper bar of the master controller is burned. If necessary, replace it.

(3) Check whether the low-voltage insurance and relay can work normally. If necessary, replace them.

#### Warning

Disconnect power before the electric check.

#### 5. CHECK OTHER PARTS

Check the torque of key fasteners.

ACCESSORY

CATEGORY, DOSAGE AND MODEL OF ACCESSORY

ITEM	ACCESSORY	DOSAGE	MODEL
CHECK GEAR OIL LEVEL	GEAR OIL	1.05L	SAE 80W-90
LUBRICATE CHAIN	MACHINE OIL	APPROPRIATE AMOUNT	20# (IN WINTER),40# (IN OTHER SEASONS)
REPLACE HYDRAULIC OIL	HYDRAULIC OIL	9 L	ISO VG46, ISO VG68

Note

The amount of accessories is marked with the maximum while the actual amount should be subject to use.

BEFORE MAINTENANCE

BEFORE MAINTENANCE

The forklift shall be placed on firm ground before maintenance. Put the handle lever in place, and then stop the forklift. Press the emergency stop switch and fix it with wedge.

EMERGENCY DESCENT

The fork cannot be lowered after the forklift broke down. At this point, Release the pressure relief switch on the hydraulic power unit and lower the fork. Then tighten the pressure relief switch.

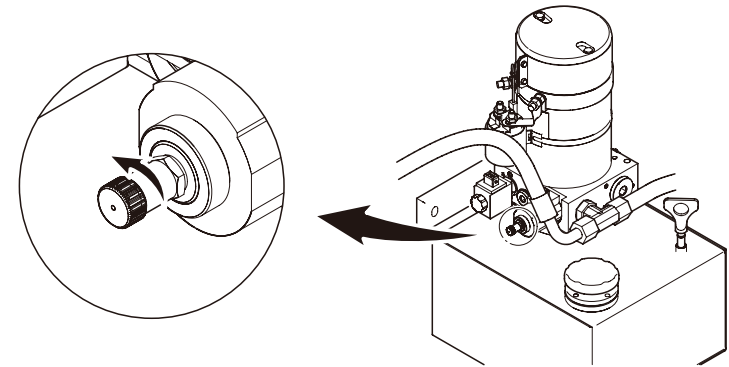

### TOWING FAULTY VEHICLES

When electric parts are faulty, the brake of the forklift is in the braking state. At this point, unscrew the screws of the brake disc first, remove the brake disc and then tow the forklift.

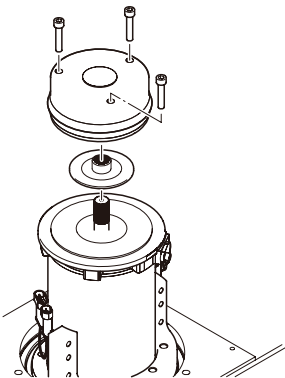

**Caution**

- (1) Tow the forklift only in the way of rigid connection.
- (2) Tow the forklift only in a low speed.

### MAINTAIN CHASSIS

#### CHECK AND ADJUST BALANCE OF THE ENTIRE FORKLIFT

If the forklift shakes during use, the balance of the entire forklift should be adjusted. After the guard plate is removed, the balance of the entire forklift should be adjusted through screws. Before adjustment, place the forklift on the solid level ground and then unscrew fixed bolts of the balance wheel assembly.

- (1) When the right front part or left rear part of the forklift shakes, the limit assembly of the balance wheel should be screwed up.
- (2) When the left front part or right rear part of the forklift shakes, the limit assembly of the balance wheel should be screwed down.

< 1 >

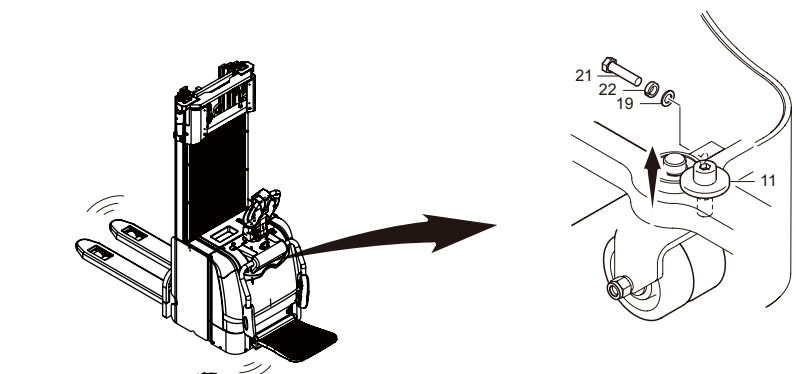

< 2 >

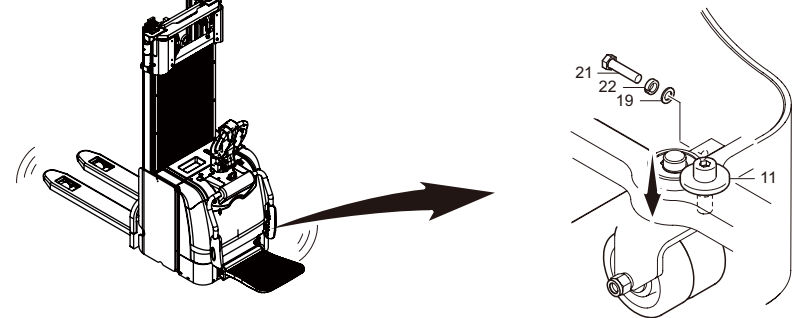

CODE	PART NAME	QTY	OTHER INFORMATION	CODE	PART NAME	QTY	OTHER INFORMATION
11	LIMIT ASSEMBLY OF THE BALANCE WHEEL	1		21	HEXAGON HEADED BOLT M12×45	1	
19	FLAT WASHER M12	1		22	LIGHT TYPE SPRING WASHER	1	



REPLACE SUPPORT WHEELS

- (1) Lift the front end of the fork till the support wheel is rotated 90 degrees, and then pad with a piece of solid wood.
- (2) Unscrew the screw. Replace the support wheel and then rotate 180 degrees. Replace another support wheel.
- (3) Replace the support wheel of the fork on the other side.

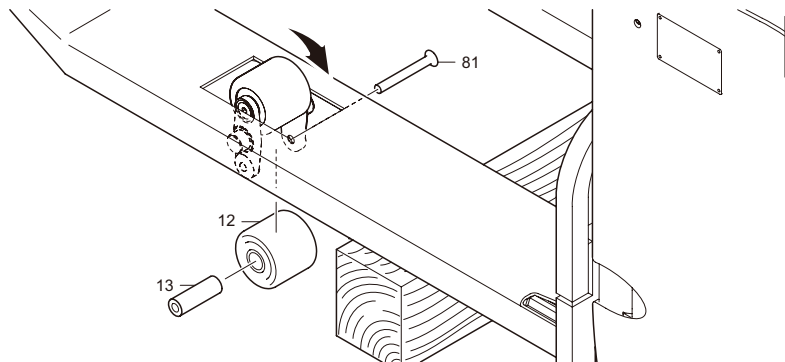

CODE	PART NAME	QTY	OTHER INFORMATION	CODE	PART NAME	QTY	OTHER INFORMATION
12	SUPPORT WHEEL	4		81	HEXAGON SOCKET SET SCREWS WITH FLAT OIN	4	90 N-m
13	BUSHING	4					

Caution

- (1) The support wheel should be replace completely.
- (2) After the wheel is replaced, the balance of the forklift shall be checked and adjusted.

REPLACE BALANCE WHEELS

- (1) Jack up the rear of the forklift and pad with solid wood. Unscrew the nut and remove the balance wheel.
- (2) Unscrew nuts and bolts and then replace balance wheels.

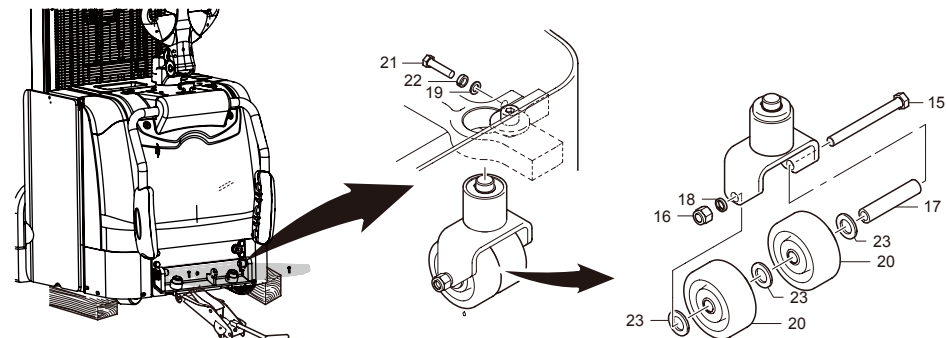

CODE	PART NAME	QTY	OTHER INFORMATION	CODE	PART NAME	QTY	OTHER INFORMATION
15	HEXAGON HEADED BOLT M16×160	1		20	BALANCE WHEEL	2	
16	NUT M16	1	110 N-m	21	HEXAGON HEADED BOLT M12×45	1	90 N-m
17	SLEEVE OF THE BALANCE WHEEL	1		22	LIGHT TYPE SPRING WASHER	1	
18	HEAVY TYPE SPRING WASHER M16	1		23	FLAT WASHER	3	
19	FLAT WASHER M12	1					

Caution

After wheels are replaced, the balance of the entire forklift shall be checked and adjusted.

REPLACE DRIVE WHEELS

Jack up the rear of the forklift and pad with solid wood. Unscrew the nut and replace the drive wheel.

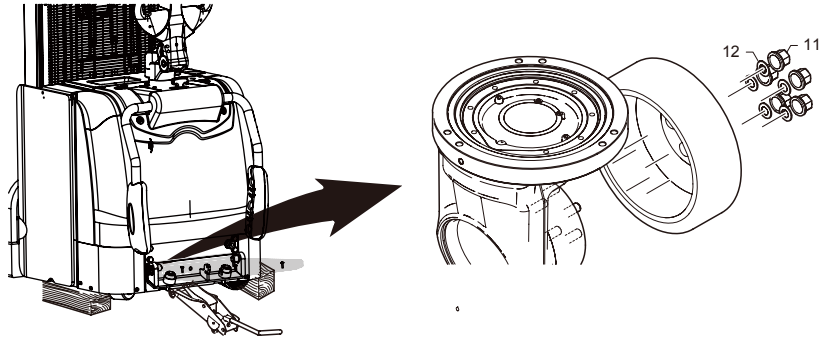

CODE	PART NAME	QTY	OTHER INFORMATION
11	HEXAGON FLANGE NUT	5	90 N-m
12	SPHERICAL SPRING WASHER	5	

Caution

After wheels are replaced, the balance of the entire forklift shall be checked and adjusted.

CHECK LEVEL OF GEAR OIL AND ADD GEAR OIL

- (1) Clean the surrounding area of the oil fill plug and unscrew it.
- (2) Check the level of gear oil. Determine whether the oil level is just below the lower edge of the nozzle. If not enough, add gear oil.
- (3) After check, Install the oil fill plug and its seals and tighten it.

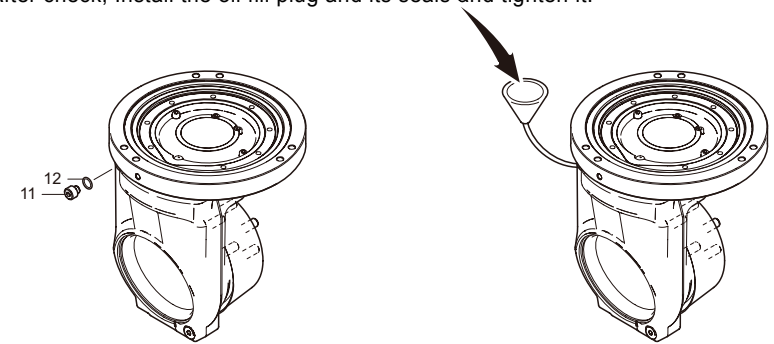

CODE	PART NAME	QTY	OTHER INFORMATION
11	OIL FILL PLUG	1	30 N-m
12	SEAL RING	1	

Caution

- (1) Pay attention to your surroundings when refueling and keep dust and moisture out of the tank.
- (2) The oil level should be just below the nozzle.

REPLACE GEAR OIL

- (1) Clean the oil fill plug and the surrounding area of the oil drain plug. Place an appropriate container under the oil drain plug.
- (2) Unscrew the the oil fill plug and the oil drain plug.
- (3) After oil drains, install the oil drain plug and its new seal, and then tighten it.
- (4) Add gear oil till the lower edge of the nozzle. Install the oil fill plug and its seals and tighten it.

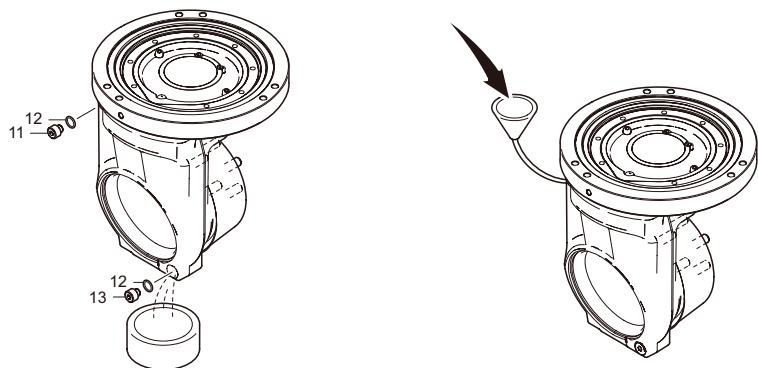

CODE	PART NAME	QTY	OTHER INFORMATION	CODE	PART NAME	QTY	OTHER INFORMATION
11	OIL FILL PLUG	1	30 N-m	13	OIL DRAIN PLUG	1	30 N-m
12	SEAL RING	2					

**Caution**

- (1) The time for draining cannot exceed 5 minutes.
- (2) Pay attention to your surroundings when refueling and keep dust and moisture out of the tank.
- (3) Waste oil must be disposed of away from people and can't be dumped in waterways or on the ground.
- (4) The oil level should be at the lower edge of the nozzle.

MAINTAIN MAST

ADJUST CHAIN

The main lifting chain should be adjusted in the standard mast while free lift chain is for free mast. Stop on the flat ground and lower down the fork fully.

Close the vehicle, unplug the key and press the emergency stop button. Then adjust chain.

1. ADJUST CHAIN OF STD MAST

Unscrew upper and lower nuts on the main lift chain. Adjust chain length by adjusting themiddle nut. After adjustment, the fork should be kept level, and the left and right chains should bear same tightness. Then tighten the nut.

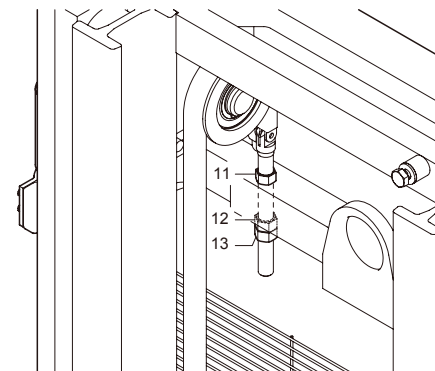

CODE	PART NAME	QTY	OTHER INFORMATION	CODE	PART NAME	QTY	OTHER INFORMATION
11	NUT (UPPER)	1	110 N-m	13	NUT (LOWER)	1	110 N-m
12	NUT (MIDDLE)	1	110 N-m				

**Caution**

After adjusting the chain, the chain should not be slack when the lift cylinder is in the initial position.

2. ADJUST CHAIN OF FULLY FREE MAST

- (1) Unscrew upper and lower nuts on the main lift chain. Adjust chain length by adjusting the middle nut. After adjustment, keep the left and right chains with same tightness and tighten the nut.

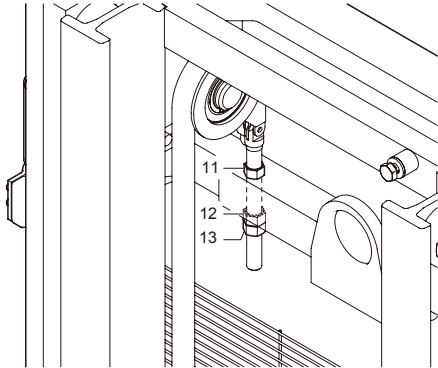

CODE	PART NAME	QTY	OTHER INFORMATION	CODE	PART NAME	QTY	OTHER INFORMATION
11	NUT (UPPER)	1	110 N-m	13	NUT(LOWER)	1	110 N-m
12	NUT (MIDDLE)	1	110 N-m				

- (2) Unscrew upper and lower nuts on the free lift chain. Adjust chain length by adjusting the middle nut. After adjustment, the fork should be kept level, and the left and right chains should bear same tightness. Then tighten the nut.

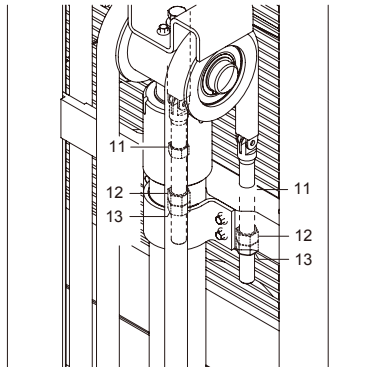

CODE	PART NAME	QTY	OTHER INFORMATION	CODE	PART NAME	QTY	OTHER INFORMATION
11	NUT (UPPER)	1	110 N-m	13	NUT(LOWER)	1	110 N-m
12	NUT (MIDDLE)	1	110 N-m				

LUBRICATE CHAIN

- (1) Clean surface of the chain and remove dust and debris
- (2) Add lubricating oil and ensure it permeates clearance of chain joints.
- (3) Lift mast several times after lubricating.

CLEAN MAST

Remove dirt and debris insert in the mast.

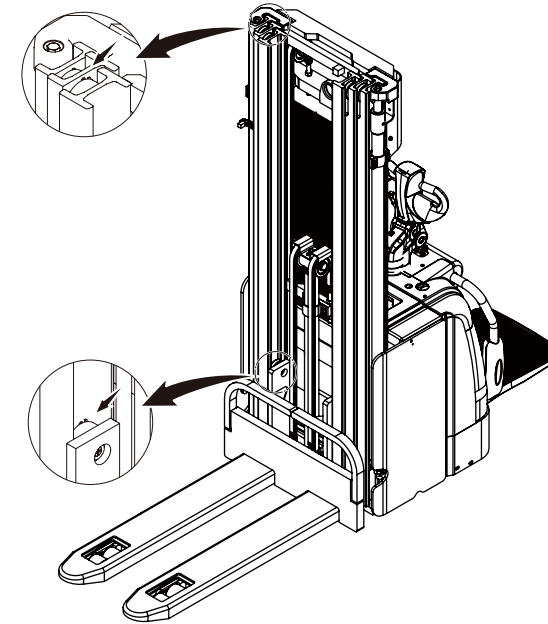

ADJUST MAST CLEARANCE

1. MAST ROLLER DESCRIPTION

The main roller, side roller and dust ring are installed onto the mast or fork carriage through retaining rings. The side roller is used to adjust mast clearance by adjusting screws on the other side. The anti-loosing piece is used to protect adjusting screws.

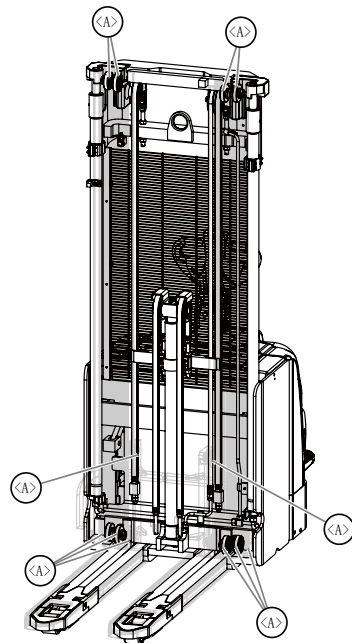
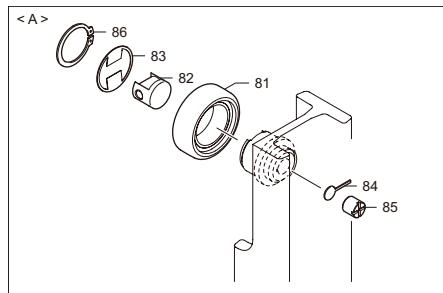

CODE	PART NAME	QTY	OTHER INFORMATION	CODE	PART NAME	QTY	OTHER INFORMATION
81	MAIN BEARING OF COMPOUND ROLLER	12		84	ANTI-LOOSING PIECE OF COMPOUND ROLLER	12	110 N-m
82	SIDE BEARING OF COMPOUND ROLLER	12		85	ADJUSTING SCREWS OF COMPOUND ROLLER	12	
83	DUST-PROOF PIECE OF COMPOUND ROLLER	12		86	RETAINING RINGS FOR SHAFT	12	

2. COMMON METHOD FOR ADJUSTING CLEARANCE BETWEEN FORK CARRIAGE AND MAST

- (1) Lift mast and show where the adjusting screws are.
- (2) Bend the anti-loosing piece and show adjusting screws.
- (3) Use adjusting screws to adjust mast clearance.
- (4) After adjustment, bend the anti-loosing piece to protect screws.

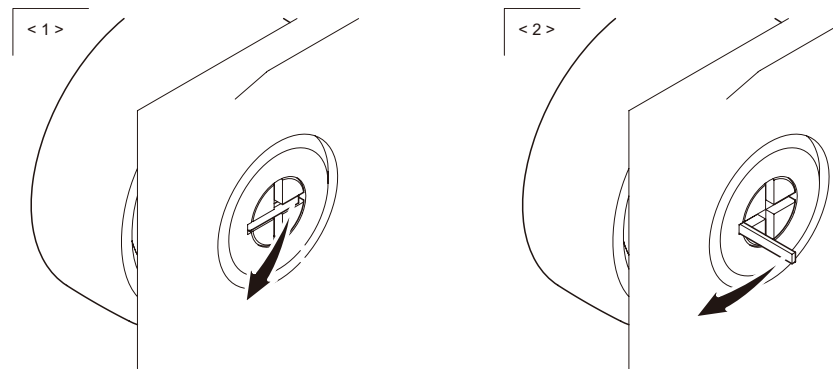

3. REGULATORY SEQUENCE

2-STAGE MAST:

- (1) Clearance between outer mast and inner mast.
- (2) Clearance between inner mast and fork carriage.

3-STAGE MAST:

- (1) Clearance between outer mast and middle mast.
- (2) Clearance between middle mast and inner mast.
- (3) Clearance between inner mast and fork carriage.

## MAINTAIN HYDRAULIC DEVICE

### ADD HYDRAULIC OIL

- (1) Pull out the oil gauge. Wipe the oil off with a clean cloth and insert the gauge into the tank again.
- (2) Pull out the oil gauge and check whether the level of hydraulic oil is in the scale.
- (3) If the level of hydraulic oil is below the scale, open the cover of the oil filling filter and add the oil.

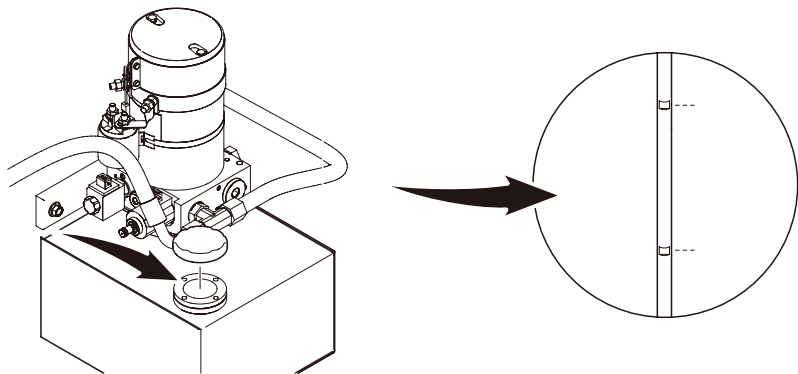

#### Caution

- (1) Pay attention to surroundings when refueling and keep dust and moisture out of the tank.
- (2) Don't mix hydraulic oil.
- (3) Waste oil must be disposed of away from people and can't be dumped in waterways or on the ground.
- (4) Using unauthorized hydraulic oil can damage the hydraulic system and thereby Only authorized hydraulic oil can be used. If you need hydraulic oil of other specifications, please contact after-sale personnel of BYD Forklift.

### REPLACE HYDRAULIC OIL

- (1) Disconnect connection between hydraulic power unit and the oil hose, and then remove the hydraulic power unit and the oil tank assembly.
- (2) Remove the oil tank from the hydraulic power unit. Pour out the hydraulic oil in the tank and then re-add it.

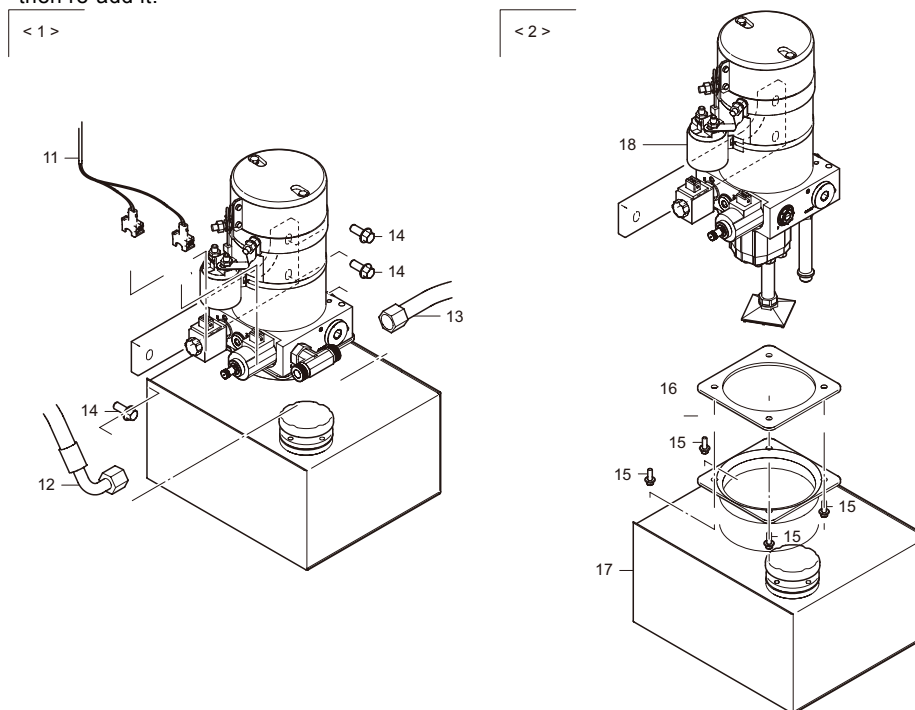

CODE	PART NAME	QTY	OTHER INFORMATION	CODE	PART NAME	QTY	OTHER INFORMATION
11	SIGNAL WIRE	1		15	BOLT	4	
12	OIL HOSE	1		16	RUBBER MAT	1	
13	OIL HOSE	1		17	OIL TANK	1	
14	BOLT	3		18	HYDRAULIC POWER UNIT	1	

#### Caution

- (1) Pay attention to surroundings when refueling and keep dust and moisture out of the tank.
- (2) Don't mix hydraulic oil.
- (3) Waste oil must be disposed of away from people and can't be dumped in waterways or on the ground.
- (4) Using unauthorized hydraulic oil can damage the hydraulic system and thereby Only authorized hydraulic oil can be used. If you need hydraulic oil of other specifications, please contact after-sale personnel of BYD Forklift.

## MAINTAIN ELECTRIC DEVICE

### Warning

Disconnect power before the electric check.

### CHECK CIRCUIT

- (1) Check whether connection terminals of the electric device are loose. If any, tighten it.
- (2) Check whether the wiring connection is normal (for example, whether it is burnt).
- (3) Check whether the connection sheath is loose. If any, tighten it.

### CHECK THE MAIN CONTROLLER

1. Check whether connection terminals of the main controller are loose. If any, tighten it.
2. Check whether the safety device of the main controller works normally. If necessary, replace it.
3. Check whether the copper bar of the main controller is burnt. if any, replace it.

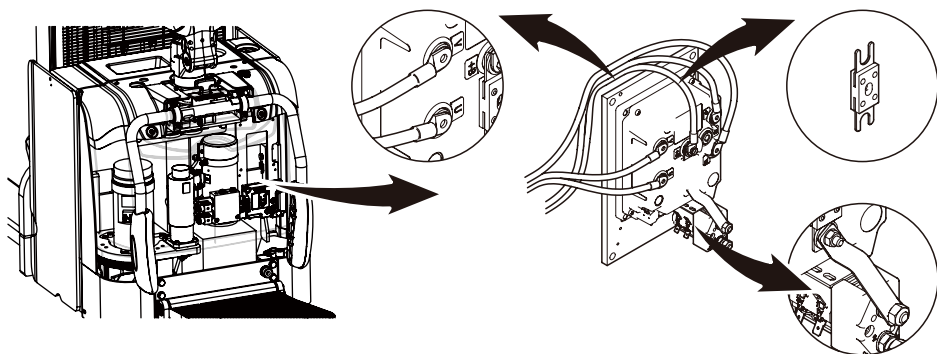

### CHECK LOW-VOLTAGE SAFETY DEVICE AND RELAY

Check whether the low-voltage safety device and relay works normally. Replace them if necessary.

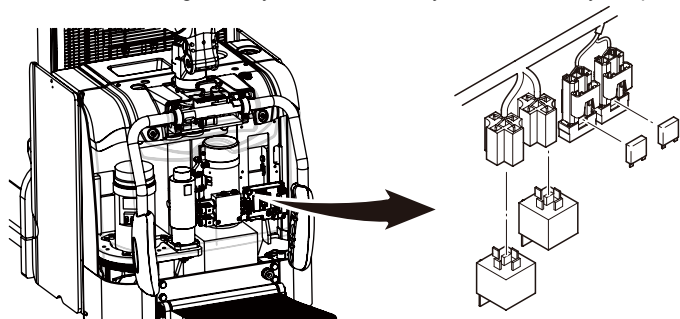

## CHECK TORQUE OF KEY FASTENERS

### CHECK TORQUE OF WHEEL FASTENERS

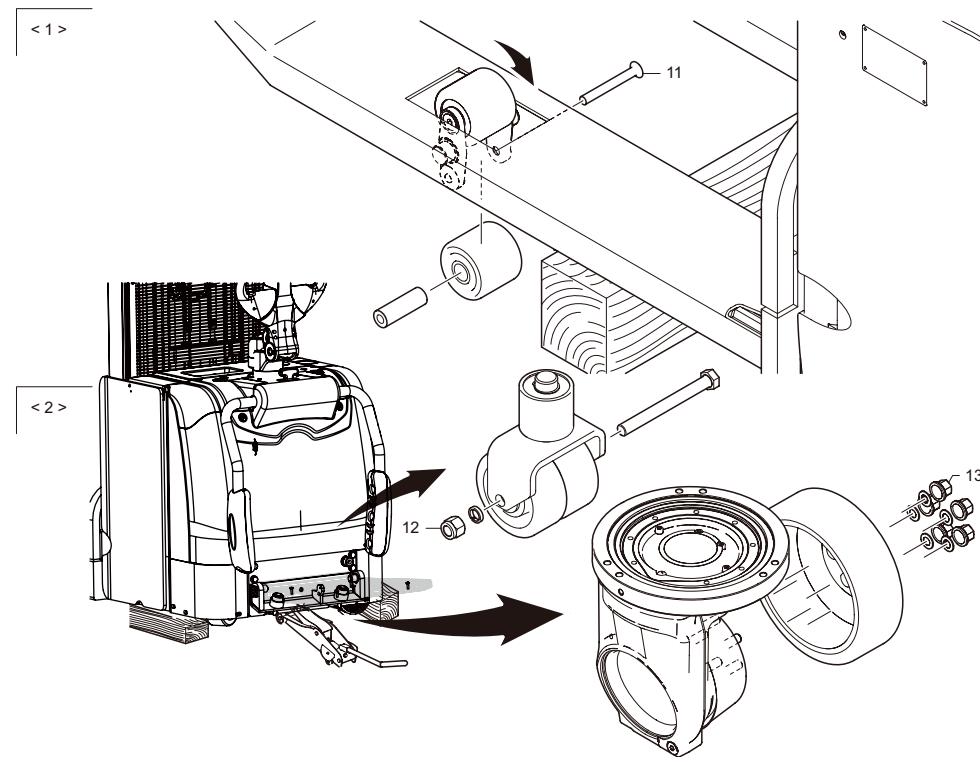

CODE	PART NAME	QTY	OTHER INFORMATION	CODE	PART NAME	QTY	OTHER INFORMATION
11	FIXED SCREW OF THE SUPPORT WHEEL	4	90 N-m	13	FIXED NUT OF THE DRIVE WHEEL	1	90 N-m
12	FIXED NUT OF THE BALANCE WHEEL	2	110 N-m				

CHECK FASTENERS TORQUE OF THE MAST

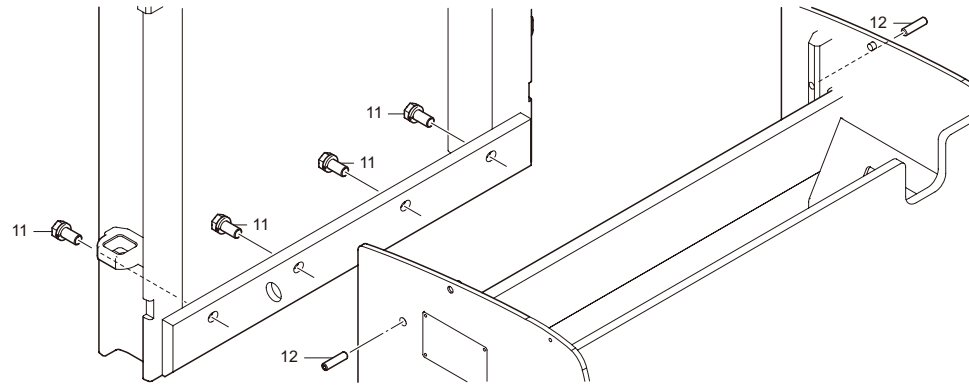

CODE	PART NAME	QTY	OTHER INFORMATION
11	BOLTS FOR FIXING MAST WITH FORKLIFT BODY	4	100 N-m
12	SCREW FOR CONNECTING MAST WITH THE FORKLIFT BODY	2	30 N-m

SCHEMATIC DIAGRAMS

HYDRAULIC SCHEMATIC DIAGRAM

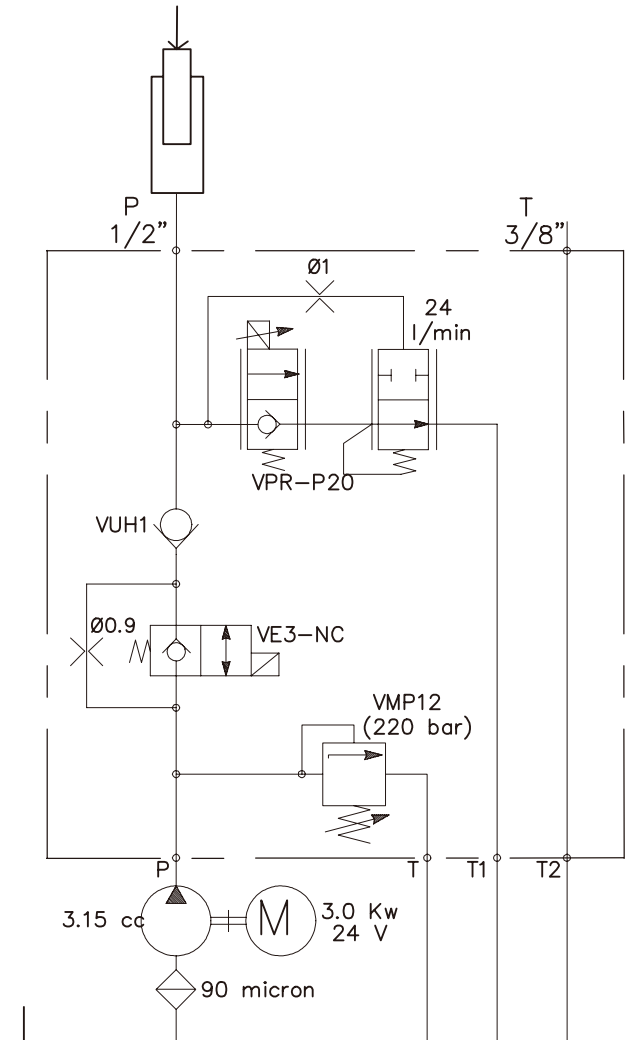



ELECTRICAL SCHEMATIC DIAGRAM

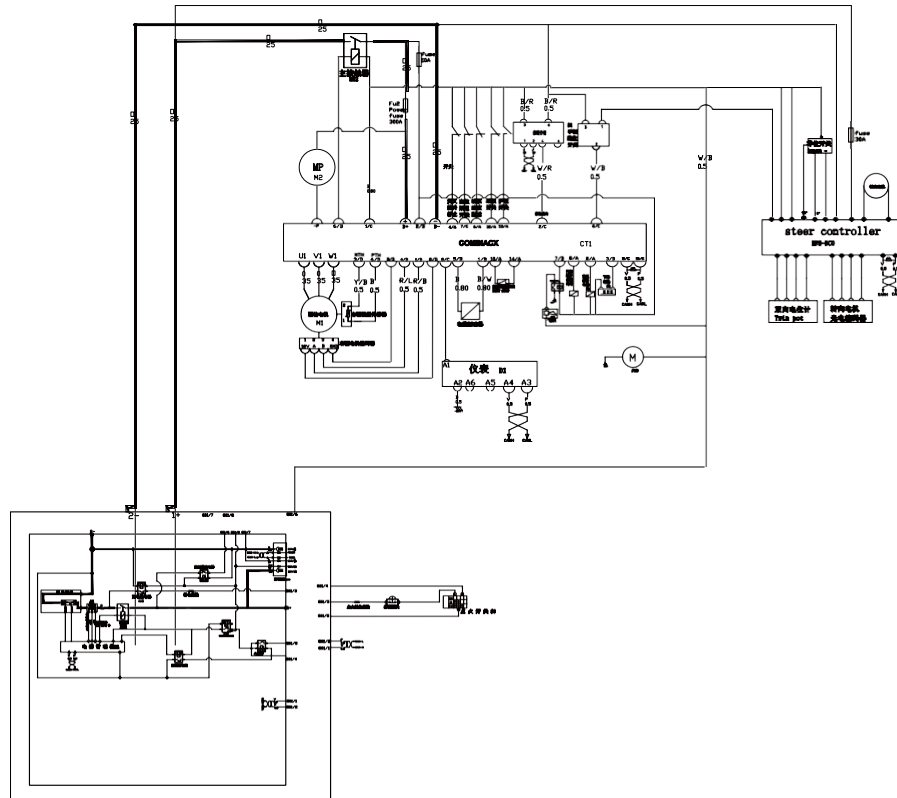

TABLE OF FAULT CODES

TABLE OF FAULT CODES

FAULT CODE	ALARM	REMEDY
02A00	BATTERY LOW	If parameters of "BATTERY CHECK" are not set as "0", the fault will be reported, and the lifting function will be locked when the battery power is less than 15% and no bars are displayed on the instrument. Please charge in time. If the battery is electric, check whether the value of "ADJUST BATTERY" on the controller is consistent with that of battery voltage. Charge the battery.
	EPS RELE OPEN	Check if the EPS controller is faulty.
	DATA ACQUISITION	If the fault is activated to show that it is in a phase of data acquisition, please wait until data is acquired completely. Don't operate during data acquisition. Restart after data is acquired.
	CHECK UP NEEDED	When the maintenance time is up, check it. Revise CHECK UP DONE into ON. Shut down and restart
02A01	WRONG CONFIG	Clear EEPROM
02A08	WATCHDOG	Watchdog circuit will be activated before software starts. Under working or standby states, the signal of watchdog is ineffective (warning state). Fault analysis: a broken state has been seen in the watchdog hardware circuit or the microcontroller output part. If both of the above two are irrelevant with outer parts, replace the controller.
	FLASH CHECKSUM	After the key is turned on, the value of flash checksum on the program is positive. If it is negative, the signal of fault will appear. Fault analysis: It is blamed for the flash memory of microcontroller. The flash checksum may be broken, or the program stored suffered from damage. Try to reset the program of the logic card. If the fault continues, it should be blamed for the microcontroller. Replace the controller.
	WATCHDOG#2	Cause: The Watchdog circuit will be activated before software starts. Under working or standby states, the signal of watchdog is ineffective (warning state). Fault analysis: A broken state has been seen in the watchdog hardware circuit or the microcontroller output part. If both of the above two are irrelevant with outer parts, replace the controller.
02A10	WRONG RAM	Find faults when performing tests for main ram: the registration address is "DIRTY". The fault will limit the operability of forklifts. Fault analysis: Close the key switch and open again. If the fault still exists, replace the controller.
02A11	STALL ROTOR	1.Motor stalls. 2.Fault appears in the encoder of the motor. 3.Wiring harnesses is broken or fault is found in the wiring. 4.The encoder is disabled in its power supply.
02A13	EEPROM KO	1. Restart the electric lock. Please replace the controller if the fault still exists. 2. Restart the electric lock. Please reset parameters if the fault disappears. Perform CLEAR EEPROM. If the fault disappears, change the parameters as set values singly. Instead, try to replace the controller.
	PARAM RESTORE	If CLEAR EEPROM has been performed, change the prompt parameters of fault as a default value. If not, there is a fault inside the controller.
02A16	AUXOUTPUT KO	Check whether the coil of electromagnetic brake is normal. If not, replace the controller.
02A17	LOGIC FAILURE #3	The output circuit of coil suddenly disconnects during operation. A fault is found in the current protection function of the logic card. Replace the controller.
02A18	LOGIC FAILURE #2	1. Check whether the circuit of motor power line is normal, including the safety device of the controller. 2. Check the parameter list. 3. If it is not blamed for the above two, replace the controller.
02A19	LOGIC FAILURE #1	1. Check battery voltage. 2. Check whether ADJUST BATTERY of the controller is consistent with actual voltage of the battery.
02A20	HEIGHT SENS OPEN	
02A21	CHARGE SAFETY	When it is charging, any movement of forklifts will report the fault. It can protect forklifts from being operated when charging.
02A22	HEIGHT SENS LOCK	
	RESET CUTBACK 1	

FAULT CODE	ALARM	REMEDY
02A26	CURRENT SENS. KO	
02A27	PHASE KO	Check whether the connection among U/V/W is normal.
02A28	PUMP VMN LOW	Cause: When the machine starts, the low-end voltage of MOS transistor is 10% higher than that of normal battery or the phase voltage is 50% higher than battery voltage. Possible causes: 1. The wiring of the motor is incorrect or a fault is found in the circuit of the motor; check whether the three-phase connection is correct; check whether there is electric leakage in the motor connecting to the ground; check whether the coil of the motor is broken. 2. Replace the controller.
02A29	PUMP VMN HIGH	Cause: When the machine starts, the low-end voltage of MOS transistor is 10% higher than that of normal battery or the phase voltage is 50% higher than battery voltage. Possible causes: 1. The wiring of the motor is incorrect or a fault is found in the circuit of the motor; check whether the three-phase connection is correct; check whether there is electric leakage in the motor connecting to the ground; check whether the coil of the motor is broken. 2. Replace the controller.
02A30	vmn low	Check the three-phase line of the motor.
02A31	vmn high	Cause: When the machine starts, the low-end voltage of MOS transistor is 10% higher than that of normal battery or the phase voltage is 50% higher than battery voltage. Possible causes: 1. The wiring of the motor is incorrect or a fault is found in the circuit of the motor; check whether the three-phase connection is correct; check whether there is electric leakage in the motor connecting to the ground; check whether the coil of the motor is broken. 2. Replace the controller.
02A32	PUMP VMN NOT OK	
02A37	contactor closed	Check whether the master contactor adheres.
02A38	contactor open	1. The circuit of the master contactor coil disconnects. 2. The main contactor is broken.
02A40	AUX DRIV.SHRT.	Check whether the short circuit or low impedance push-pull output exists between A16 and -BATT. If a circuit fault appears in the driver of the logic card, replace the controller.
02A41	WRONG BATTERY	When starting, check battery voltage with the controller and determine whether it reaches what is allowed. 1. Check whether the value of BATTERY VOLSIGNE on the TESTER menu is consistent with that on the voltmeter. If not, use ADJUST BATTERY function and change the battery voltage to match the measured value. 2. Replace the battery.
02A42	AUX DRIV.OPEN	The driving circuit of the auxiliary coil can't drive load. The device itself or driving coil is broken. Replace the controller.
02A47	EVP2 NOT OK	Check whether the input voltage of NAUX2 is normal. If not, re-mark the maximum and minimum values of NAUX2 and restart the key. Then the fault disappears.
02A48	EVP1 NOT OK	Check whether the input voltage of NAUX1 is normal. If not, re-mark the maximum and minimum values of NAUX1 and restart the key. Then the fault disappears.
02A49	LIFT + LOWER i=0 ever	1. Operation is inappropriate. 2. It is blamed for faults of lifting and descending switches. 3. Replace the controller. If the three-phase connection is correct, replace the controller.
02A50	EVP1 COIL OPEN	Check whether the coil of NAUX1 is set as the open circuit or whether the type of EVPI1 is set correctly.
02A51	EVP2 COIL OPEN TILLER OPEN	Check whether the coil of NAUX1 is set as the open circuit or whether the type of EVPI2 is set correctly. When the handle input switch disconnects, the master contactor will disconnect and report an alarm after about 30 seconds. The alarm will not disappear until the master contactor runs again.
02A52	PUMP I=0 EVER	Check whether it is correct in the connection among power lines of the oil-pump motor; if yes, replace the controller.

FAULT CODE	ALARM	REMEDY
02A53	STBY I HIGH	The signal output from the current sensor, detected by the microcontroller, exceeds what is allowed by the inactive current. Since the fault is irrelevant with peripheral components, just replace the controller.
	WRONG ZERO	When it starts, the feedback value on the high-end voltage of VMN is not around 2.5V. The circuit of the controller is broken. Fault analysis: recommend to check the following items. Connection inside the motor. Connection among motor power cables. Drain current between the motor and the forklift housing. If the connection of the motor is good, check the controller and replace it.
02A54	LOGIC FAILURE #1	It is a fault caused by low-voltage or over-voltage protection. Under a 24V system, the controller detects that the voltage is over 45V or below 9V; while under a 45V system, it is over 65V or below 11V. Possible causes: 1. Check whether a short circuit appears in the circuit system, such as DC-DC, brake coil, or check whether the input power of the controller is connected well. 2. Check whether the battery voltage is too low or too high. 3. Detect B+ and B- and check whether the power cable over the binding post of the master contactor is tightened well. 4. Check whether calibration parameters of controller voltage are consistent with those of actual voltage. For the hardware circuit fault with overvoltage protection on the logic card, replace the controller.
02A55	LOGIC FAILURE #2	For it is a fault on the phase-voltage feedback hardware circuit of the logic card, replace the controller.
02A56	PUMP I NO ZERO	Replace the controller
02A60	CAPACITOR CHARGE	When the electric lock is turned on, the controller will charge the capacitance through a power resistor and detect whether the capacitance is overcharged in the regulated time. If the capacitance is insufficient power and voltage thereof is still 20% lower than that of the battery, the controller will alarm and thereby the master contactor will not closed down. Possible causes: 1. If peripheral devices such as DC-DC and motor, or other devices interfere with the charging of the controller, interference on these devices should be eliminated. 2. If the charging resistance disconnects and faults are found in the charging circuit and power models, the controller should be replaced. The output signal of temperature sensor of the controller exceeds what is allowed.
02A61	THERMIC SENS. KO high temperature	The output signal of temperature sensor of the controller exceeds what is allowed. Since the fault is irrelevant with peripheral components, just replace the controller. Measure the temperature of the controller board.
02A62	TH. PROTECTION	Drop the temperature of the controller below 85°. If the fault still exists, it may be blamed for the temperature sensor or the logic board of the controller itself. Replace the controller at this time.
02A64	TILLER ERROR	Replace the controller.
02A65	MOTOR TEMPERAT.	1. The fault appears when the temperature digital switch of the motor turns on or when the analog signal exceeds the switch-off value. 2. When the temperature of the motor reaches 120°C, the controller will alarm. By this time, the forklift still can move, but the maximum current is cut and the performance of the forklift is reduced. When the temperature of the motor reaches 125°C, the motor stalls working where it should be cooled down. 3. If the fault still exists when the motor cools down, check the circuit. If necessary, replace the controller.
02A67	SENS MOT TEMP KO	The output signal of temperature sensor of the controller exceeds what is allowed. Check the value of the sensor and the connection of cables. Otherwise, it should be blamed for the inside of the controller.
	NO CAN MSG.	It is a fault about CAN communication between the steering and traction. Check the setting of CAN connection and the software, and version information.

FAULT CODE	ALARM	REMEDY
02A68	SMARTDRIVER KO	Check whether there is a short circuit between the high-end driver of the electromagnetic brake (CNB#1) and B-. Otherwise, the internal drive model may be damaged.
	WAITING FOR NODE	If a controller connected to another controller can't communicate smoothly under the CAN communication network, it will be always in a waiting state until all the CAN communication network works smoothly. Find out the reason why those model connections can't communicate smoothly, and check whether the version of the software or set of parameters is correct.
02A70	encoder error	Check the encoder of the motor.
	EPS RELAY OPEN	Check whether EPS controller is faulty.
02A71	EEPROM KO	If a fault is found in the storage area of parameters, the forklift will stop moving. If the fault still exists after the electric lock is closed repeatedly, the logic card shall be replaced. If the fault disappears, parameters stored previously will be replaced by wrong ones and thereby being reset.
	HANDBRAKE handbrake	
02A72	VMN LOW	Causes: when starting, the high-end voltage of MOS transistor is 66% lower than that of the capacitance or it is lower than what is required during the operation of the motor. Possible causes: 1. The connection or circuit of the motor is incorrect; check the three phase connection of the motor is correct; check whether there is electric leakage in the motor connecting to the ground or the coil of the motor disconnects. 2. Check whether the suction of the master contactor is firm and whether the contact is worn. 3. Replace the controller.
02A73	sens. Motor temp.ko	Check wire harness of the temperature sensor of the motor.
02A74	DRIVER SHORTED	Check whether a short circuit appears in the coil output by the controller. If any, replace the controller.
	AUX BATT. SHORT.	Check whether the connection between B1 and B5 is correct. If yes, replace the controller.
	DRV. SHOR. EV	Check whether a short circuit appears between the low-end of EV1/EV2/EV3 and B-. If yes, replace the controller.
02A75	C O N T A C T O R CLOSED	Before closing down the coil of the master contactor, the controller detects whether contacts of the master contactor adhere at first. Try to discharge the capacitor. If the capacitor voltage reduces the battery voltage by 20%, a fault may occur. Recommend to check whether contacts of the contactor adhere or to replace the controller.
	CONTACTOR DRIVER	When the electric lock is closed down, microcontroller will detect whether a short circuit appears in the driver of the master contactor. If any, it will alarm. Check whether a short circuit appears when the positive pole of the main contactor coil connects to A16 or the negative pole of power supply. If the outer part is normal, replace the controller.
	CONT. DRV. EV	Replace the controller.
02A76	KEY OFF SHORTED	In the starting phase, a fault will appear when the controller detects that a low logic level signal is found in disconnecting the key switch. Fault analysis: it is likely that the voltage is too low. Recommend to check the following items: -The key switch is based on external load. (For example, DC-DC converter starts, and the input signal of the relay or contactor is lower than starting voltage.) -Check the connection among the power cable and positive and negative terminals of battery, and that among the power cable and -BATT and +BATT of the master contactor and controller. Use screws to connect with a torque range of 13NM+15NM. -Voltage drop will be detected on the power supply cable when the key switch is turned ON every time. Fault signal: The fault may occur in the hardware of the controller and thereby it is necessary to replace the controller.
	COIL SHOR. MC-EB	1. Check whether the output and load of the controller are too high. 2. Replace the controller.
	COIL SHOR. EV.	If there is a fault in a coil driven by PEV, check whether the connection between the coil driven by PEV and the coil itself is good.
	coil shorted	Check whether a short circuit appears in the coils of the master contactor and oil pump contactor.
02A77	CONTACTOR OPEN	1. The coil of the master contactor disconnects. 2. The master contactor is broken.
	end teach ko	Not included in BYD system.

FAULT CODE	ALARM	REMEDY
02A78	VACC NOT OK	Detecting time: the standby state The alarm displays that the voltage of the accelerator is at least 1V higher than the minimum value set in the accelerator signal (PROGRAM VACC). Possible causes: 1. The upper and lower voltage limits of the accelerator are not collected. Enter the PROGRAM VACC menu and Recollect again. 2. Error occurs in the accelerator wherein its pedal doesn't return, or error occurs inside the accelerator. 3. A fault occurs in the controller.
	BACKING INPUT	
02A79	INCORRECT START	Possible reasons why the device starts in a wrong order are as follows: 1. Before starting up, the direction switch has been closed down. 2. The device is operated in a wrong order. 3. The wire connection is incorrect. 4. If a fault cannot be eliminated, the controller shall be replaced.
	WRONG STEER PAR.	
	PUMP INC START	Possible reasons why the oil pump starts in a wrong order are as follows: 1. Before starting up, switches such as those for lifting and tilting have been closed down. 2. The device is operated in a wrong order. 3. The wire connection is incorrect. 4. If a fault cannot be eliminated, the controller shall be replaced.
02A80	FORW + BACK	The controller will always detect and alarm when requests from two directions run signals at the same time. Possible causes are as follows. 1. The wire is broken. 2. A fault appears in the direction switch. 3. The operation is improper. 4. If a fault cannot be eliminated, the controller shall be replaced.
	EMERGENCY	
02A82	ENCODER ERROR	The controller detects that the two consecutive speed readings of the encoder are quite different. Since the encoder inside the system is impossible to change the speed to a large degree in a very short time, the encoder may fail (The wiring of one or two encoders is worn or broken). Check mechanical and circuit functions of the encoder. The alarm may be caused by electromagnetic interference on the sensor bearing. If not the above causes, replace the controller. Please note: Manual operation may also cause that the controller displays the fault, and thereby the forklift needs to be powered off to restart. For example: 1. The forklift bumps into an obstacle suddenly, making itself impossible to move. 2. A driver slams on the brakes when the forklift is moving at high speed.
02A84	CAN BUS KO BMS	Check whether the BMS communication circuit is normal.
	canbus ko bms	Check the BMS communication circuit.
02A85	VACC OUT RANGE	1. The upper and lower voltage limits of the accelerator are not collected. Enter the PROGRAM VACC menu and Recollect again. 2. Check whether the connection of the accelerator is correct.
02A86	PEDAL WIRE KO	Check whether positive and negative terminals of the accelerator are connected to the controller.
	POS. EB. SHORTED	When the interlock is not closed down, the high-end driver of the electromagnetic brake outputs high voltage. 1. Check if any other high voltage circuits are connected to the heightened outlets of electromagnetic brakes. 2. Otherwise, the high voltage still exists and the driving circuit inside the controller has been broken.

FAULT CODE	ALARM	REMEDY
02A89	POWER MOS SHORT	The software will check the power bridge before the master contactor closes down wherein the power bridge will be converted into low-end power and phase voltage will be reduced to -BATT (rise to +BATT). If the phase voltage value doesn't vary with the indicator, the fault signal will occur. Replace the controller.
	PUMP VACC NOT OK	Detecting time: the standby state The alarm displays that the voltage of the accelerator is at least 1V higher than the minimum value set in the accelerator signal ( PROGRAM VACC ). Possible causes: The upper and lower voltage limits of the accelerator are not collected. Enter the PROGRAM VACC menu and Recollect again.
	pev not ok	Not included in BYD system.
02A90	PUMP VACC RANGE	1. The upper and lower voltage limits of the accelerator are not collected. Enter the PROGRAM VACC menu and Recollect again. 2. Check whether the lift speed-sensor is connected correctly.
	lift+lower	Check whether the signal of the handle switch is normal.
02A91	lift low active	Check the lowering switch triggered at startup.
02A92	CURRENT GAIN	The maximum current gain parameter is the factory set value, showing that the program of maximum current adjustment parameter has not been enabled. Solutions: ZAPI technicians set the current gain parameters correctly.
	canbus ko tiller	Handle communication fault.
02A93	wrong battery	Check whether the battery works normally.
02A94	data acquisition	It is not allowed to change the set of controller parameters when the controller works.
02A95	INPUT ERROR #2	
02A96	ANALOG INPUT	When A/D input by analog signals is converted into a fixed value, the fault signal appears where delay time exceeds 400ms.
		The function is used to detect A/D converter fault or analyze conversion fault of analog signal. If the fault persists, replace the controller.
02A97	input error#1	Check whether A13 input is normal.
02A98	reload hm from mdi	Not included in BYD system.
	input error#2	Check whether A14 input is normal.
02A99	SLIP_PROFILE	Parameter selection of SLIP PROFILE is wrong. Check values of these parameters in hardware setup parameters.
	checkout needed	Please consult the after-sale personnel during maintenance time.

FAULT CODE	ALARM	REMEDY
06A00	STEER HAZARD	1、 Reduce the turning angle and restart it. 2、 Change the internal angle parameter setting of the steering controller;
	EMERGENCY	Close the interlock switch again after emergency reverse to eliminate this fault.
	WAITING DATA	1. Check if CAN BUS communication cable is connected well; 2. Check if the communication baud rate is consistent;
	EPS NOT ALIGNED	1. Check if the zero-position proximity switch is in place; 2. Check if the selection of zero-position proximity switch is correct; 3. Check if the output data of zero-position proximity switch is correct;
	WAITING FOR TRAC	1. Check if CAN BUS communication cable is connected well; 2. Check if the interlock switch cable is correct; 3. If the interlock switch is controlled by the handle, TILLER SEITCH should be set to HANDLE;
06A01	KEYOFF	1. Check whether the key switch voltage receives a low voltage pulse when the external load is turned on; 2. Check if B +, B- are connected to the controller firmly; 3. Replace the controller if this fault is reported every time you open the key;
	HIGH CURRENT	1. Check if the steering controller matches the motor ; 2. Replace the controller ;
06A02	POWER FAILURE #1	1. Check if the controller vital is normal; 2. Check if the power cord is firmly connected to the controller; 3. Check if the controller's W phase wire is connected well; 4. Replace the controller;
06A03	POWER FAILURE #2	1. Check if the controller vital is normal; 2. Check if the power cord is firmly connected to the controller; 3. Check if the controller's U phase wire is connected well; 4. Replace the controller;
06A04	POWER FAILURE #3	1. Check if the controller vital is normal; 2. Check if the power cord is firmly connected to the controller; 3. Check if the controller's V phase wire is connected well; 4. Replace the controller ;
06A05	STBY I HIGH	The controller checks whether the motor current is zero in the standby state of the vehicle. If not, the fault will occur and the vehicle will stop working immediately. The possible causes are: 1. The terminal end is directly connected to another load rather than to a walking motor, such as a lifting motor. 2. Current sensor or logic card were damaged. Replace the logic card first. If the fault still exists, replace the power part.
06A06	D LINE SENSOR KO	1. Check if the stepper motor cable is intact; 2. The resistance between the D line and B- is too small (close to 30Ω)
06A07	Q LINE SENSOR KO	1. Check if the stepper motor cable is intact; 2. The resistance between the Q line and B- is too small (close to 30Ω);
06A08	EEPROM KO	If the vehicle does not walk, there is a problem with the parameter storage area, which stops the vehicle from working. If the fault still exists after repeatedly closing the electric lock, replace the logic card. If the fault disappears, the originally stored parameters will be replaced by the wrong parameters and need to be reset.
06A09	VMN NOT OK	Replace the controller;
06A10	HIGH TEMPERATURE	At this time, the maximum current of the controller decreases as the temperature increases. When the temperature is 105℃, the controller current is reduced to zero. The fault occurs when the chopper is in the cold state: 1. The temperature calibration parameters of the logic card are incorrect so you need to check the parameters. 2. The temperature sensor inside the controller is faulty. 3. Check whether the temperature sensor itself is damaged.

FAULT CODE	ALARM	REMEDY
06A11	DATA ACQUISITION	This activated fault proves that it is in the data acquisition phase. Please wait until the data acquisition is complete.
06A12	LOGIC FAILURE #1	A fault that occurs in the low-voltage or over-voltage protection state. In a 24V system, the controller detects a voltage of more than 45V or less than 9V; In a 48V system, the controller detects a voltage of more than 65V or less than 11V. The possible causes are: 1. Whether there is a short circuit in the circuit system, such as DC-DC, brake coil, etc., or whether the input power of the controller is in good condition. (walking controller) 2. Whether the battery voltage is too low or too high. (walking controller) 3. Whether the power cables on the terminals such as B+, B, and the main contactor are fastened. (walking controller) 4. Whether the voltage calibration parameter of controller is consistent with the actual voltage. (walking controller) 5. The hardware circuit of the over-voltage protection on the logic card is faulty. Replace the controller. (walking controller) 6. The voltage between W phase and U phase does not meet the requirements. Replace the controller. (steering controller)
06A13	LOGIC FAILURE #2	The voltage between W phase and V phase does not meet the requirements. Replace the controller. (steering controller)
06A14	LOGIC FAILURE #3	The output VU-VV of the voltage amplifier exceeds 2.2V-2.8V. Replace the controller (steering controller).
06A15	LOGIC FAILURE #4	The output VW-VV of the voltage amplifier exceeds 2.2V-2.8V. Replace the controller (steering controller).
06A16	KS CLOSED	The main contactor detects that the safety contactor of the slave contactor is closed in advance. Replace the controller.
06A17	KM CLOSED	The slave contactor detects that the safety contactor of the main contactor is closed in advance. Replace the controller.
06A18	KS OPEN	The main contactor detects that the safety contactor of the slave contactor is not closed in time. Replace the controller.
06A19	KM OPEN	The slave contactor detects that the safety contactor of the main contactor is not closed in time. Replace the controller.
06A20	MAIN CONT. OPEN	The logic card has driven the main contactor coil, but the contactor is not closed. Possible causes are as follows: 1. Mechanical failure of contactor or stuck, etc. 2. Poor contact of the contactor. 3. If the contactor works properly, replace the controller.
06A21	MICRO SLAVE	Replace the controller.
06A22	S.P OUT OF RANGE	If a single potentiometer, such as CPOC1 end, exceeds the range of 0.8v-4.2v, an alarm will be raised. When a dual potentiometer is selected, the sum of the two sliding ends (CPOC1+CPOC2) exceeds the range of 4.4v-5.5v, an alarm will be raised. Check the connection of the potentiometer.
06A23	F.B OUT OF RANGE	When the feedback potentiometer (CPOT connected to CNB # 6) is faulty, an alarm will be raised. If the range of CPOT exceeds the range 0.3V-4.7V, an alarm will be raised. Check if the steering motor encoder is connected correctly and whether there is a circuit break.
06A24	MICRO SLAVE KO	1. When a stepper motor is used, the direction of the main microprocessor is inconsistent with that of the stepper motor detected from the slave microprocessor. 2. In the closed-loop control system, the direction of the stepper motor detected by the main contactor is wrong and inconsistent with the direction of the stepper motor detected from the slave contactor. 3. The main contactor did not detect the steering limit, but the slave contactor did.
06A25	ENCODER ERROR	The controller detected a significant difference in the two consecutive speed readings of the encoder since the internal encoder cannot change the speed very much in a short time. Check the mechanical and circuit functions of the encoder to make sure if the encoder is faulty (the circuit of one or two encoders is worn or broken); Or the alarm may be caused by electromagnetic interference on the sensor bearing. If neither, replace the controller. Please note that manual operation may also cause this fault. In this case, you need to power off and restart the vehicle. For example: 1.The vehicle suddenly hit an obstacle and was unable to walk; 2. Slam on the brake at high speed.
06A26	BAD ENCODER SIGN	Exchange encoder A phase and B phase;
06A27	GAIN EEPROM KO	Replace the controller;

FAULT CODE	ALARM	REMEDY
06A28	CAN BUS KO	1. Check if CAN BUS communication cable is connected well; 2. Check if the communication baud rate is consistent; 3. Check if CAN communication is on; 4. Check if CAN communication loop resistance is 60Ω.
06A38	POSITION	1. Check if the connection of A phase and B phase of steering motor encoder is loose. 2. Check if A phase and B phase of the steering motors are disturbed.
06A39	SERIAL ERROR	Replace the controller.
06A40	MICRO SLAVE #4	Replace the controller.
06A41	SLAVE COM. ERROR	Replace the controller.
06A43	CURRENT GAIN	Replace the controller.
06A44	CLOCK PAL NOT OK	Replace the controller.
06A45	STEER SENSOR KO	Check if the wiring and output of two-way angle potentiometer is correct.
06A46	JERKING FB	Replace feedback potentiometer;
06A47	FB POT LOCKED	1. Check if there is mechanical loosening of the feedback angle potentiometer; 2. Check if there is a mechanical limit; 3. Check if the feedback angle potentiometer reaches its own limit point; 4. If this fault occurs due to the reverse direction of the steering wheels during installation, adjust the direction of the steering wheels.
06A48	MOTOR TEMPERAT.	1. This fault occurs if the motor temperature digital switch is turned on, or the analog signal exceeds the cutoff value. 2. When the motor temperature reaches 120℃, the controller gives an alarm, at which point the vehicle can still walk, but the maximum current is reduced, so does the performance of the vehicle. When the motor temperature reaches 125 ℃, the motor stops working, and you should try to cool the motor. 3. If the fault still exists when the motor cools down, check the wiring. If all is good, replace the controller.
06A49	MOTOR LOCKED	The time of maximum sustained current of the steering motor exceeds 1s.
06A50	STEPPER MOT MISM	Replace the controller.
06A52	MICRO SLAVE #8	Replace the controller.
06A53	INPUT ERROR #1	Check if CAN # 4 connection cable is correct.
06A54	CAN BUS KO SL.	Replace the controller.
06A55	SL EPS NOT ALL.	Replace the controller.
06A56	SL CENTERING	Replace the controller.
16A06		Check the CAN cables of the handle, instrument and steering controller.
17A01	battery high temp.waring	
17A02	battery high temp.alarm	
17A03	battery leakage waring	
17A04	battery leakage serious	
17A05	battery Status Alarm	
17A06	BDI low	
17A07	BDI low	
17A08	BDI low	

## OTHER INFORMATION

### CONTACT INFORMATION

BYD (SHAOGUAN) CO.,LTD.

Production Address : No.1, BYD Road, Zhenjiang Industrial Zone, Shaoguan, Guangdong,

Zip Code: 512040

Tel: +86-751-810 8888

After-sales address: 2nd floor, A4, BYD Industrial Park, 1 Yan'an Road, Kwai Chung

Street, Dapeng New District, Shenzhen,

Zip Code: 518119

Tel: +86-755-2386 0828

Wbsite: [www.bydforklift.com](http://www.bydforklift.com)



*Build Your Dreams*